

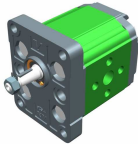

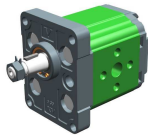



<b>XV-0P</b>		
		
References: XP-001	References: XP-012	References: XP-017
<b>Standard Ø22 FLANGE</b>	<b>Ø22 BH FLANGE</b>	<b>Ø22 HY FLANGE</b>

<b>XV-1P</b>		
		
References: XP-101	References: XP-113	References: XP-119
<b>Ø25.4 FLANGE</b>	<b>Ø30 FLANGE</b>	<b>Ø32 BH FLANGE</b>
		
References : XP-140	References: XP-161	References: XP-168
<b>Ø32 HY FLANGE</b>	<b>Standard German Ø32 BH</b>	<b>Ø50.8 SAE AA FLANGE</b>

<b>XV-2P</b>		
		
References : XP-201	References : XP-210	References: XP-213
<b>Ø36.5 FLANGE</b>	<b>Ø50 BH FLANGE</b>	<b>Ø50 HY FLANGE</b>
		
References: XP-216	References : XP-217	References : XP-219
<b>Standard German Ø52 BH FLANGE</b>	<b>Standard German Ø80 FLANGE</b>	<b>Ø82.5 SAE A FLANGE</b>

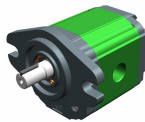
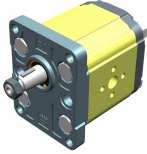
<b>XV-3P</b>	
	
References : XP-301	References : XP-331
<b>BASE Ø50,8 - Standard</b>	<b>BASE Ø101,6 SAE B</b>

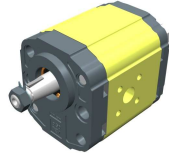
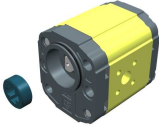
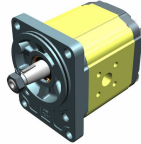
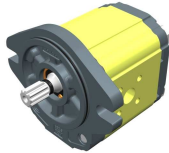
Vivoil Oleodinamica Vivoilo s.r.l. presents a new series of gear pumps called **XV-P**. The quality of the product has been improved on by exploiting new and innovative solutions, both technical and constructive, for which the company has been **awarded 3 patents**.

The pumps are divided into four groups:

**The main features of the XV-0P are the following:**

Displacements from 0.16 cm<sup>3</sup> / revolution to 2.28 cm<sup>3</sup>/revolution.

Maximum pressures up to **280 bar**.

Versions w/ flanges: Ø22 – Standard;  
Ø22 BH – Sagomata;  
Ø22 HY – Sagomata.

Rotation speeds up to **9000 rpm**.

Configurations with inlet and outlet in the body, flange and cover.

Available shafts: Cylindrical with Woodruff key;  
Milled shank;  
Tapered 1:8 Woodruff key.

**The main features of the XV-1P are the following:**

Displacements from 0.91 cm<sup>3</sup> / revolution to 9.88 cm<sup>3</sup>/ revolution.

Maximum pressures up to **300 bar**.

Versions w/ flanges: Ø25.4 – Standard European;  
Ø30 – Standard;  
Ø32 BH – Body-Shaped;  
Ø32 HY – Body-Shaped;  
Ø32 BH – Standard German – Body-Shaped;  
Ø50.8 – SAE AA

Rotation speeds up to **6000 rpm**

Configurations with inlet and outlet in the body, flange and cover.

Available shafts: Tapered 1:8 Woodruff key;  
Parallel with key;  
Milled shank;  
Splined.

**The main features of the XV-2P are the following:**

Displacements from 4.2 cm<sup>3</sup> / revolution a 39.6 cm<sup>3</sup>/ revolution.

Maximum pressures up to **300 bar**.

Versions w/ flanges: Ø36,5 – Standard Europea;  
Ø50 BH – Body-Shaped;  
Ø50 HY – Body-Shaped;  
Ø52 BH - Standard German – Body-Shaped;  
Ø80 – Standard German;  
Ø82,5 – SAE A.

Rotation speeds up to **3500 rpm**

Configurations with inlet and outlet in the body, flange and cover.

Available shafts: Tapered 1:8 Woodruff key;  
Parallel with key;  
Milled shank;  
Splined.

**The main features of the XV-3P are the following:**

Displacements from 14.89 cm<sup>3</sup> / revolution to 86.87cm<sup>3</sup>/ revolution.

Maximum pressures up to **320 bar**.

Versions w/ flanges: Ø50,8 – Standard European;

Rotation speeds up to **3000 rpm**.

Available shafts: Tapered 1:8 Woodruff key;  
Parallel with key;  
Splined.

**Summary: Displacements - Pressures - Speeds**

	Type	Displacement	Max. Pressure	Min speed	Max speed
<b>XV-0P</b>	XV-0P/0.17	0.16 cm <sup>3</sup> /rev	260 bar	700 rpm	9000 rpm
	XV-0P/0.25	0.24 cm <sup>3</sup> /rev	260 bar	700 rpm	9000 rpm
	XV-0P/0.45	0.45 cm <sup>3</sup> /rev	280 bar	700 rpm	9000 rpm
	XV-0P/0.57	0.56 cm <sup>3</sup> /rev	280 bar	700 rpm	9000 rpm
	XV-0P/0.76	0.75 cm <sup>3</sup> /rev	280 bar	700 rpm	9000 rpm
	XV-0P/0.98	0.92 cm <sup>3</sup> /rev	280 bar	700 rpm	6000 rpm
	XV-0P/1.27	1.26 cm <sup>3</sup> /rev	280 bar	700 rpm	6000 rpm
	XV-0P/1.52	1.48 cm <sup>3</sup> /rev	280 bar	700 rpm	6000 rpm
	XV-0P/2.30	2.28 cm <sup>3</sup> /rev	210 bar	700 rpm	5000 rpm
<b>XV-1P</b>	XV-1P/0.9	0.91 cm <sup>3</sup> /rev	280 bar	700 rpm	6000 rpm
	XV-1P/1.2	1.17 cm <sup>3</sup> /rev	290 bar	700 rpm	6000 rpm
	XV-1P/1.7	1.56 cm <sup>3</sup> /rev	290 bar	700 rpm	6000 rpm
	XV-1P/2.2	2.08 cm <sup>3</sup> /rev	290 bar	700 rpm	6000 rpm
	XV-1P/2.6	2.60 cm <sup>3</sup> /rev	300 bar	700 rpm	6000 rpm
	XV-1P/3.2	3.12 cm <sup>3</sup> /rev	300 bar	700 rpm	6000 rpm
	XV-1P/3.8	3.64 cm <sup>3</sup> /rev	300 bar	700 rpm	6000 rpm
	XV-1P/4.3	4.16 cm <sup>3</sup> /rev	300 bar	700 rpm	6000 rpm
	XV-1P/4.9	4.94 cm <sup>3</sup> /rev	300 bar	700 rpm	6000 rpm
	XV-1P/5.9	5.85 cm <sup>3</sup> /rev	300 bar	700 rpm	5000 rpm
	XV-1P/6.5	6.50 cm <sup>3</sup> /rev	300 bar	700 rpm	5000 rpm
<b>XV-2P</b>	XV-1P/7.8	7.54 cm <sup>3</sup> /rev	260 bar	700 rpm	5000 rpm
	XV-1P/9.8	9.88 cm <sup>3</sup> /rev	230 bar	700 rpm	4000 rpm
	XV-2P/4	4.2 cm <sup>3</sup> /rev	300 bar	700 rpm	3500 rpm
	XV-2P/6	6.0 cm <sup>3</sup> /rev	300 bar	700 rpm	3500 rpm
	XV-2P/9	8.4 cm <sup>3</sup> /rev	300 bar	700 rpm	3500 rpm
	XV-2P/11	10.8 cm <sup>3</sup> /rev	300 bar	700 rpm	3500 rpm
	XV-2P/14	14.4 cm <sup>3</sup> /rev	290 bar	700 rpm	3500 rpm
	XV-2P/17	16.8 cm <sup>3</sup> /rev	270 bar	700 rpm	3500 rpm
	XV-2P/19	19.2 cm <sup>3</sup> /rev	250 bar	700 rpm	3000 rpm
	XV-2P/22	22.8 cm <sup>3</sup> /rev	240 bar	700 rpm	3000 rpm
	XV-2P/26	26.2 cm <sup>3</sup> /rev	210 bar	700 rpm	3000 rpm
<b>XV-3P</b>	XV-2P/30	30.0 cm <sup>3</sup> /rev	200 bar	700 rpm	2500 rpm
	XV-2P/34	34.2 cm <sup>3</sup> /rev	190 bar	700 rpm	2500 rpm
	XV-2P/40	39.6 cm <sup>3</sup> /rev	180 bar	700 rpm	2000 rpm
	XV-3P/15	14.89 cm <sup>3</sup> /rev	320 bar	700 rpm	3000 rpm
	XV-3P/18	17.37 cm <sup>3</sup> /rev	320 bar	700 rpm	3000 rpm
	XV-3P/21	21.10 cm <sup>3</sup> /rev	300 bar	700 rpm	3000 rpm
	XV-3P/27	26.97 cm <sup>3</sup> /rev	270 bar	700 rpm	3000 rpm
	XV-3P/32	32.27 cm <sup>3</sup> /rev	270 bar	700 rpm	3000 rpm
	XV-3P/38	38.47 cm <sup>3</sup> /rev	270 bar	700 rpm	2800 rpm
	XV-3P/43	43.44 cm <sup>3</sup> /rev	250 bar	700 rpm	2800 rpm
	XV-3P/47	47.16 cm <sup>3</sup> /rev	250 bar	700 rpm	2800 rpm
	XV-3P/51	50.88 cm <sup>3</sup> /rev	250 bar	700 rpm	2800 rpm
	XV-3P/54	54.60 cm <sup>3</sup> /rev	250 bar	700 rpm	2300 rpm
	XV-3P/61	60.81 cm <sup>3</sup> /rev	220 bar	700 rpm	2300 rpm
XV-3P/64	64.53 cm <sup>3</sup> /rev	220 bar	700 rpm	2300 rpm	
XV-3P/70	70.74 cm <sup>3</sup> /rev	210 bar	700 rpm	2300 rpm	
XV-3P/74	74.46 cm <sup>3</sup> /rev	190 bar	700 rpm	2300 rpm	
XV-3P/90	86.87 cm <sup>3</sup> /rev	160 bar	700 rpm	2300 rpm	

**General technical data**

Type of fluid to be used	Mineral-based hydraulic oil HLP HV (D IN 51524)
Minimum operating viscosity	10 mm <sup>2</sup> /s
Maximum operating viscosity	100 mm <sup>2</sup> /s
Maximum admissible viscosity at start-up	1500 mm <sup>2</sup> /s
Recommended viscosity	20 mm <sup>2</sup> /s - 100 mm <sup>2</sup> /s
Ambient temperature	-20 °C - 60°C
Fluid operating temperature	-15°C - 80°C
Recommended fluid operating temperature	30°C - 50° C
For temperatures above 120°C	Request FKM seals ( V iton)
Max. inlet fluid suction pressure (IN)	0.02-0.08 bars
Max. inlet fluid pressure (IN)	0.3 - 0.5 bars (for higher pressures consult the manufacturer)
Inlet fluid filtering (IN)	30 - 60 Microns
Outlet fluid filtering (OUT)	10 - 25 Microns
Max. inlet fluid speed (IN)	0.5 - 1.5 m/s
Max. outlet fluid speed (OUT)	3.0 - 5.5m/s
Use of water-glycol (HF-C)	max n. of revolutions 1100 rpm; max pressure 170 bars

**Flow rate tables**

TYPE	cm3/ rev	Flow rate l/min	rpm														Flow rate l/min		
			700	1000	1500	2000	2500	3000	3500	4000	4500	5000	5500	6000	7000	8000		9000	
XV 0P/0.17	0,16	Flow rate l/min	0,106	0,152	0,228	0,304	0,380	0,456	0,532	0,608	0,684	0,760	0,836	0,912	1,064	1,216	1,368	Flow rate l/min	
XV 0P/0.25	0,24		0,160	0,228	0,342	0,456	0,570	0,684	0,798	0,912	1,026	1,140	1,254	1,368	1,596	1,824	2,052		
XV 0P/0.45	0,45		0,299	0,428	0,641	0,855	1,069	1,283	1,496	1,710	1,924	2,138	2,351	2,565	2,993	3,420	3,848		
XV 0P/0.57	0,56		0,372	0,532	0,798	1,064	1,330	1,596	1,862	2,128	2,394	2,660	2,926	3,192	3,724	4,256	4,788		
XV 0P/0.76	0,75		0,499	0,713	1,069	1,425	1,781	2,138	2,494	2,850	3,206	3,563	3,919	4,275	4,988	5,700	6,413		
XV 0P/0.98	0,92		0,612	0,874	1,311	1,748	2,185	2,622	3,059	3,496	3,933	4,370	4,807	5,244					
XV 0P/1.27	1,26		0,838	1,197	1,796	2,394	2,993	3,591	4,190	4,788	5,387	5,985	6,584	7,182					
XV 0P/1.52	1,48		0,984	1,406	2,109	2,812	3,515	4,218	4,921	5,624	6,327	7,030	7,733	8,436					
XV 0P/2.30	2,28		1,516	2,166	3,249	4,332	5,415	6,498	7,581	8,664	9,747	10,830							

TYPE	cm3/ rev	Flow rate l/min	rpm											Flow rate l/min	
			700	1000	1500	2000	2500	3000	3500	4000	4500	5000	5500		6000
XV 1P/0.9	0,91	Flow rate l/min	0,630	0,900	1,350	1,800	2,250	2,700	3,150	3,600	4,050	4,500	4,950	5,400	Flow rate l/min
XV 1P/1.2	1,17		0,840	1,200	1,800	2,400	3,000	3,600	4,200	4,800	5,400	6,000	6,600	7,200	
XV 1P/1.7	1,56		1,190	1,700	2,550	3,400	4,250	5,100	5,950	6,800	7,650	8,500	9,350	10,200	
XV 1P/2.2	2,08		1,540	2,200	3,300	4,400	5,500	6,600	7,700	8,800	9,900	11,000	12,100	13,200	
XV 1P/2.6	2,6		1,820	2,600	3,900	5,200	6,500	7,800	9,100	10,400	11,700	13,000	14,300	15,600	
XV 1P/3.2	3,12		2,240	3,200	4,800	6,400	8,000	9,600	11,200	12,800	14,400	16,000	17,600	19,200	
XV 1P/3.8	3,64		2,660	3,800	5,700	7,600	9,500	11,400	13,300	15,200	17,100	19,000	20,900	22,800	
XV 1P/4.3	4,16		3,010	4,300	6,450	8,600	10,750	12,900	15,050	17,200	19,350	21,500	23,650	25,800	
XV 1P/4.9	4,94		3,430	4,900	7,350	9,800	12,250	14,700	17,150	19,600	22,050	24,500	26,950	29,400	
XV 1P/5.9	5,85		4,130	5,900	8,850	11,800	14,750	17,700	20,650	23,600	26,550	29,500			
XV 1P/6.5	6,5		4,550	6,500	9,750	13,000	16,250	19,500	22,750	26,000	29,250	32,500			
XV 1P/7.8	7,54		5,460	7,800	11,700	15,600	19,500	23,400	27,300	31,200	35,100	39,000			
XV 1P/9.8	9,88		6,860	9,800	14,700	19,600	24,500	29,400	34,300	39,200					

TYPE	cm3/rev		rpm							
			700	1000	1500	2000	2500	3000		3500
XV 2P/4	4,2	Flow rate l/min	2,800	4,000	6,000	8,000	10,000	12,000	14,000	Flow rate l/min
XV 2P/6	6		4,200	6,000	9,000	12,000	15,000	18,000	21,000	
XV 2P/9	8,4		6,300	9,000	13,500	18,000	22,500	27,000	31,500	
XV 2P/11	10,8		7,700	11,000	16,500	22,000	27,500	33,000	38,500	
XV 2P/14	14,4		9,800	14,000	21,000	28,000	35,000	42,000	29,000	
XV 2P/17	16,8		11,900	17,000	25,500	34,000	42,500	51,000	59,500	
XV 2P/19	19,2		13,300	19,000	28,500	38,000	47,500	57,000		
XV 2P/22	22,8		15,400	22,000	33,000	44,000	55,000	66,000		
XV 2P/26	26,2		18,200	26,000	39,000	52,000	65,000	78,000		
XV 2P/30	30		21,000	30,000	45,000	60,000	75,000			
XV 2P/34	34,2		23,800	34,000	51,000	68,000	85,000			
XV 2P/40	39,6		28,000	40,000	60,000	80,000				

TYPE	cm3/rev		rpm							
			700	1000	1500	2000	2300	2500		3000
XV 3P/15	14,89	Flow rate l/min	9,90	14,15	21,22	28,29	32,54	35,37	42,44	Flow rate l/min
XV 3P/18	17,37		11,55	16,51	24,76	33,01	37,96	41,26	49,52	
XV 3P/21	21,10		14,03	20,04	30,06	40,08	46,10	50,11	60,13	
XV 3P/27	26,97		17,94	25,62	38,43	51,24	58,93	64,05	76,86	
XV 3P/32	32,27		21,46	30,65	45,98	61,31	70,50	76,63	91,96	
XV 3P/38	38,47		25,58	36,55	54,82	73,09	84,06	91,37		
XV 3P/43	43,44		28,88	41,26	61,89	82,53	94,91	103,16		
XV 3P/47	47,16		31,36	44,80	67,20	89,60	103,04	112,00		
XV 3P/51	50,88		33,84	48,34	72,51	96,67	111,17			
XV 3P/54	54,60		36,31	51,87	77,81	103,75	119,31			
XV 3P/61	60,81		40,44	57,77	86,65	115,54	132,87			
XV 3P/64	64,53		42,91	61,31	91,96	122,61	141,00			
XV 3P/70	70,74		47,04	67,20	100,80	134,40	154,56			
XV 3P/74	74,46		49,52	70,74	106,11	141,47	162,70			
XV 3P/90	86,87		57,77	82,53	123,79	165,05	189,81			

**TORQUES ALLOWED ON SHAFT:**

FORMULA FOR EVALUATING SHAFT		SHAFT [IDENTIFIER] - CODE - DESCRIPTION	T.2 [Nm]
$T.2 \leq \frac{vi \times \Delta p}{20 \times \pi \times \eta m}$ <p>T.2 = max. torque allowed by shaft [ Nm]</p>	<b>XV-0P</b>	[A] - CI001 - Parallel ø 7 - M 7x1 - key thk sp.2	2
		[B] - CF001 - Milled shank ø 7 - sp. 5	9,2
		[F] - CF005 - Milled shank ø 7 - sp.4,5 L = 9	8
	<b>XV-1P</b>	[A] - CI001 - Parallel ø12 - M10x1 - key thk. 3	25,8
		[B] - CI002 - Parallel ø12.7 - key thk. 3.2 (SAE)	32,8
		[C] - CF001 - Milled shank ø10 - thk.5 ("BH" Standard German)	13,8
		[D] - CF002 - Milled shank ø10 - thk.5	13,8
		[E] - CF003 - Milled shank ø11 - thk.6.63 (SAE)	25,8
		[F] - CO001 - Tapered 1:8 - ø10 - M7x1 - key thk.2.4	43
		[G] - CO002 - Tapered 1:8 - ø14 - M10x1 - key thk.3	119,8
		[ I ] - CO004 - Tapered 1:8 - ø12.7 - 5/16" 24UNF-2A - key thk.3.2 (SAE)	90,4
		[J] - SCF04 - Splined ø11.7 - z=6, H=17.5, m=1.6, DIN 5482 12x9	22,6
		[K] - SCF05 - Splined ø12.344, z=9, H=19, SAE J498 9T 20/40DB	32,2
		[L] - SCF02 - Splined ø11.9, z=15, H=17.5, m=0.75	42,8
		[O] - CO002+HK - Tapered 1:8 - ø14 - M10x1, HK 14-12, key thk.3	119,8
		[P] - CI001+HK - Parallel ø12 - M10x1 with bearing HK 14-12 - key thk.3	25,8
		[Q] - SCF01 - Splined ø11.9, z=15, H=9, m=0.75	42,8
	[R] - SCF03 - Splined ø11.9, z=15, H=9, m=0.75	42,8	
	<b>XV-2P</b>	[A] - CI001 - Parallel ø15 - M6x1 - key thk.4	44.1
		[B] - CI002 - Parallel ø15.875 - 1/4"28-UNF key thk.4 (SAE A)	67.5
		[C] - CF001 - Miled shank ø15 - thk.8 ("BH" Standard German)	60.5
		[E] - CO001 - Tapered 1:8 - ø17,4 - M12x1,5 - key thk.4	233.2
		[F] - CO002 - Tapered 1:5 - ø17,4 - M12x1,5 - key thk.3	233.2
		[G] - SCF02 - Splined ø16,5 - z=9, H=13, m=1.6 DIN 5482 17x14	86.1
		[H] - SCF03 - Splined ø16.5 - z=9, H=18,8, m=1,6 DIN 5482 17x14	86.1
		[ I ] - SCF04 - Splined ø15.456 z=9, H=22.5, SAE J498 9T 16/32DP	67.1
		[K] - SCF05 - Splined ø16.5 z=9 H=8,1 m=1.6 DIN 5482 17x14	86.2
[L] - SCF01 - Splined ø16.5 z=9 H=9,2 m=1.6 DIN 5482 17x14		86.2	
[M] - CO001 - Tapered 1:8 - ø17,4 - M12x1,5 - key thk.3,2	233.2		
<b>XV-3P</b>	[A] - CO001 - Tapered 1:8 - ø22 - M14x1.5 - key thk.4	482	
	[B] - CI001 - Parallel ø20 - M8 - key thk.5	181	
	[C] - SCF03 - Splined ø21.5, z=13, H=25, m=1,6	223	
	[H] - CI004 - Parallel ø22.225- 1/4"28-UNF key thk.6.35 (SAE B)	180	
	[ I ] - SCF04 - Splined ø21.8059, z=13, H=25, SAE J498 9T 16/32DP	264	

**NOTES:**

For assemblies with a coupling, you should choose one as balanced as possible in order to reduce the vibrations and dynamic stresses to which the pump shaft may be subject.

**Always make sure that the torque applied is less than or equal to the admissible torque of the shaft.**

Do not apply a direct axial or radial load on the pump shaft; if necessary, use suitable supports.

Always use well-filtered oils containing no water or other emulsifying substance.

Never run the pump with oil and air solutions.

For pumps with outlets on the flange, it is recommended not to exceed a flow rate of

4 l/min	XV-0P
20 l/min.	XV-1P
35 l/min	XV-2P

## Useful calculation formulas

SYMBOL, UNIT OF MEASUREMENT, DESCRIPTION		
qv	l/min	Flow rate
vi	cm <sup>3</sup> /rev.	Displacement (volume of oil displaced per complete revolution of the shaft)
n	rpm	Shaft rotation speed
p1	bar	inlet pressure
p2	bar	outlet pressure
Δp	bar	Δp=p2 - p1 difference between outlet (OUT) and inlet (IN) pressure
Ph	kW	Hydraulic power delivered
Pm	kW	Mechanical power absorbed
T	Nm	Torque absorbed by shaft
ηv	-	0.91 – 0.96 volumetric efficiency (volumetric ratio between operation under load and loadless operation)
ηm	-	0.85 – 0.90 mechanical efficiency
ηt	-	ηt = ηv x ηm total efficiency

Basic Formulas	Derived Formulas	
$qv = \frac{vi \times n}{1000} \times \eta v$	$vi = \frac{qv \times 1000}{n \times \eta v}$	$n = \frac{qv \times 1000}{vi \times \eta v}$
$T = \frac{vi \times \Delta p}{20 \times \pi \times \eta m}$	$vi = \frac{T \times 20 \times \pi \times \eta m}{\Delta p}$	$\Delta p = \frac{T \times 20 \times \pi \times \eta m}{vi}$
$Ph = \frac{qv \times \Delta p}{600}$	$qv = \frac{Ph \times 600}{\Delta p}$	$\Delta p = \frac{Ph \times 600}{qv}$
$Pm = \frac{vi \times \Delta p \times n}{600000 \times \eta m}$	$vi = \frac{Pm \times 600000 \times \eta m}{\Delta p \times n}$	$\Delta p = \frac{600000 \times \eta m}{vi \times n}$

## Constructive features

PART	MATERIAL	MECHANICAL FEATURES
<b>PUMP BODY</b>	Extruded alloy Series 7000, heat treated and anodised	Rp = 345 N/mm <sup>2</sup> (Yield strength) Rm = 382 N/mm <sup>2</sup> (Breaking strength)
<b>FLANGE AND COVER</b>	Die-cast aluminium alloy with excellent mechanical features, heat treated and anodised	Rp = 310÷350 N/mm <sup>2</sup> (Yield strength) Rm = 350÷400 N/mm <sup>2</sup> (Breaking strength)
<b>GEAR BUSH BEARINGS</b>	Special heat-treated tin alloy with excellent mechanical features and high anti-friction capacity. Self-lubricating bushes DU	Rp = 350 N/mm <sup>2</sup> (Yield strength) Rm = 390 N/mm <sup>2</sup> (Breaking strength)
<b>GEARS</b>	Steel UNI 7846	Rs = 980 N/mm <sup>2</sup> (Yield strength) Rm = 1270÷1570 N/mm <sup>2</sup> (Breaking strength)
<b>SEALS</b>	A 727 Standard Acrylonitrile F 975 Viton FKM	70 Shore, thermal resistance 120°C 80 Shore, thermal resistance 200°C
<b>BACK-UP RINGS</b>	Virgin PTFE Tecnil Q3	

**XV-0P CHARACTERISTIC FLOW RATE CURVES**

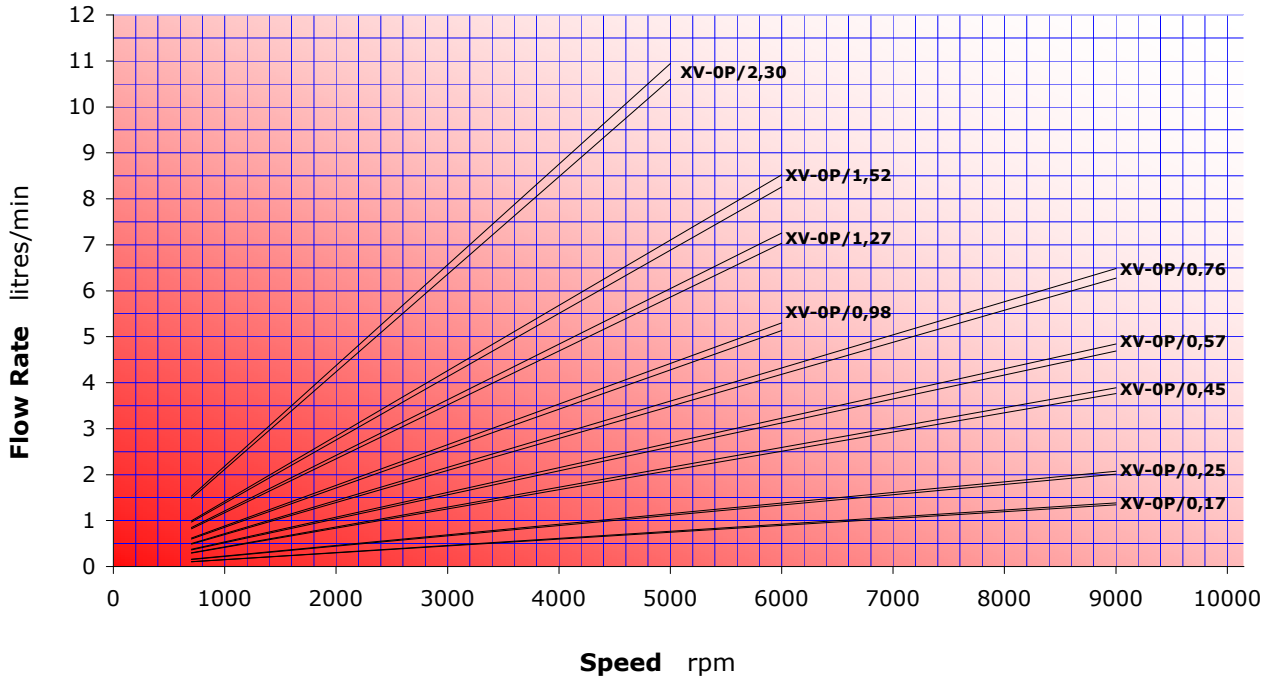

**XV-0P MOTOR TORQUE**

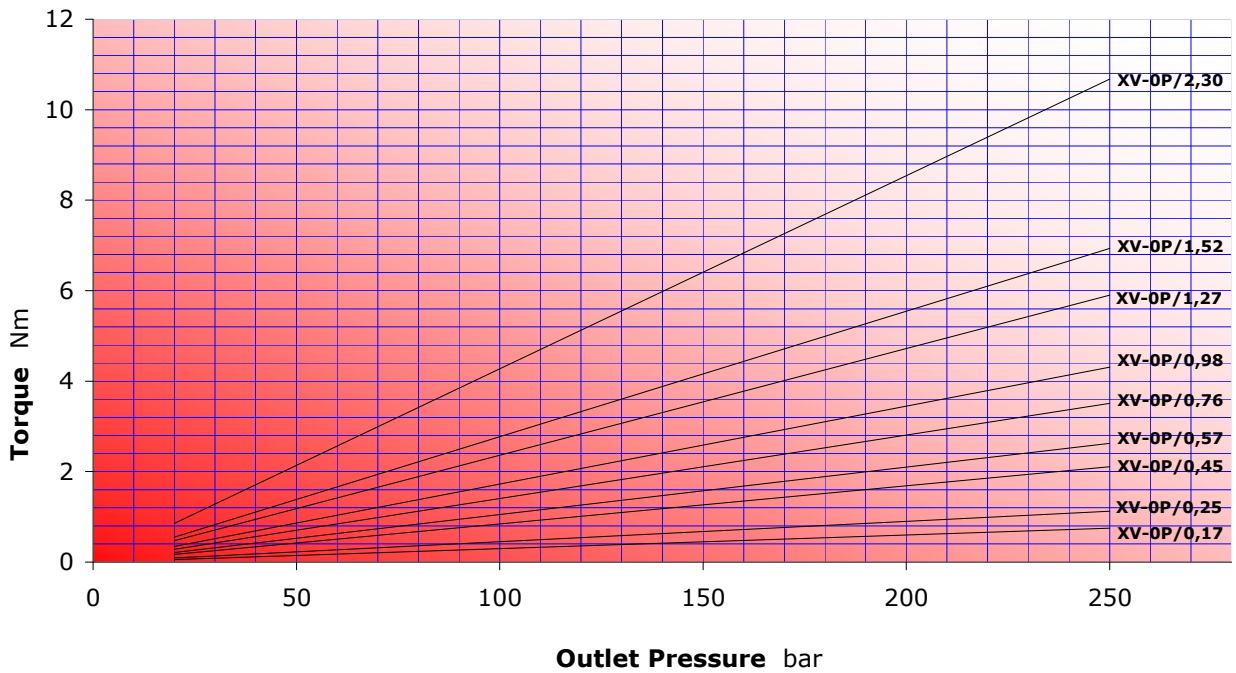



**XV-1P CHARACTERISTIC FLOW RATE CURVES**

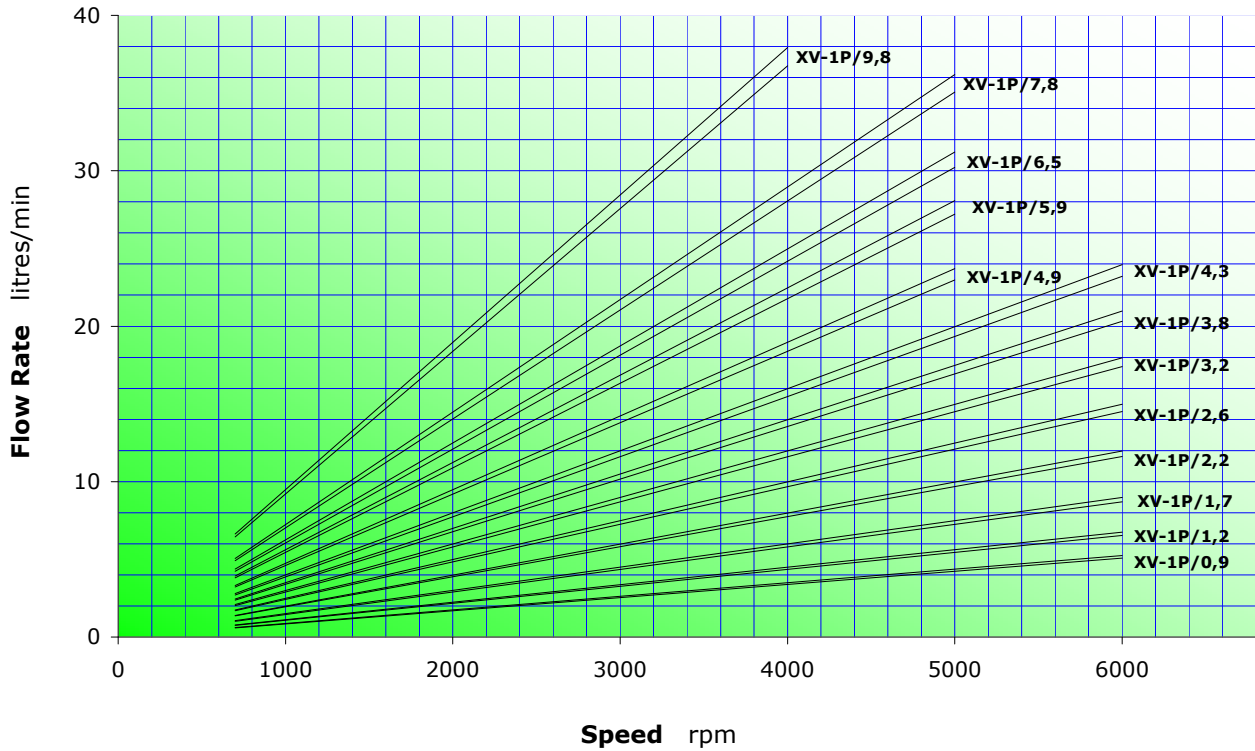

**XV-1P MOTOR TORQUE**

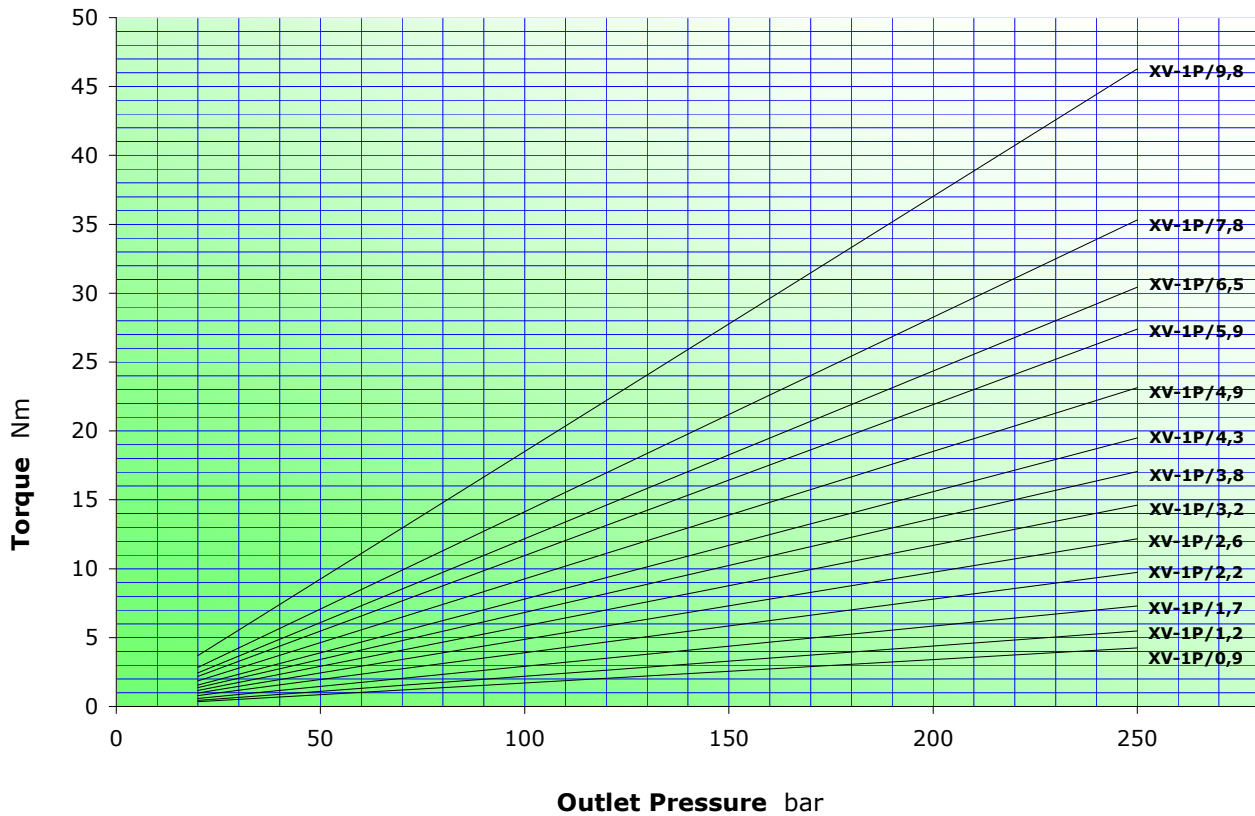

**XV-2P CHARACTERISTIC FLOW RATE CURVES**

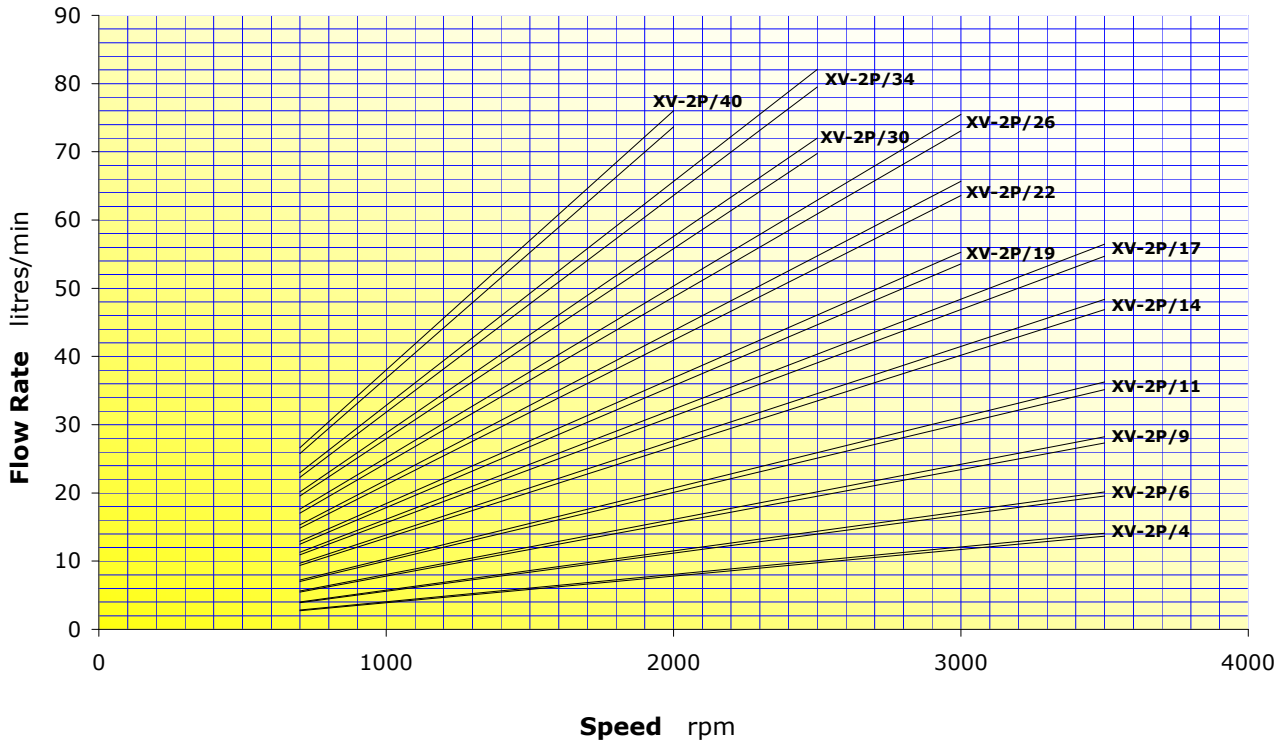

**XV-2P MOTOR TORQUE**

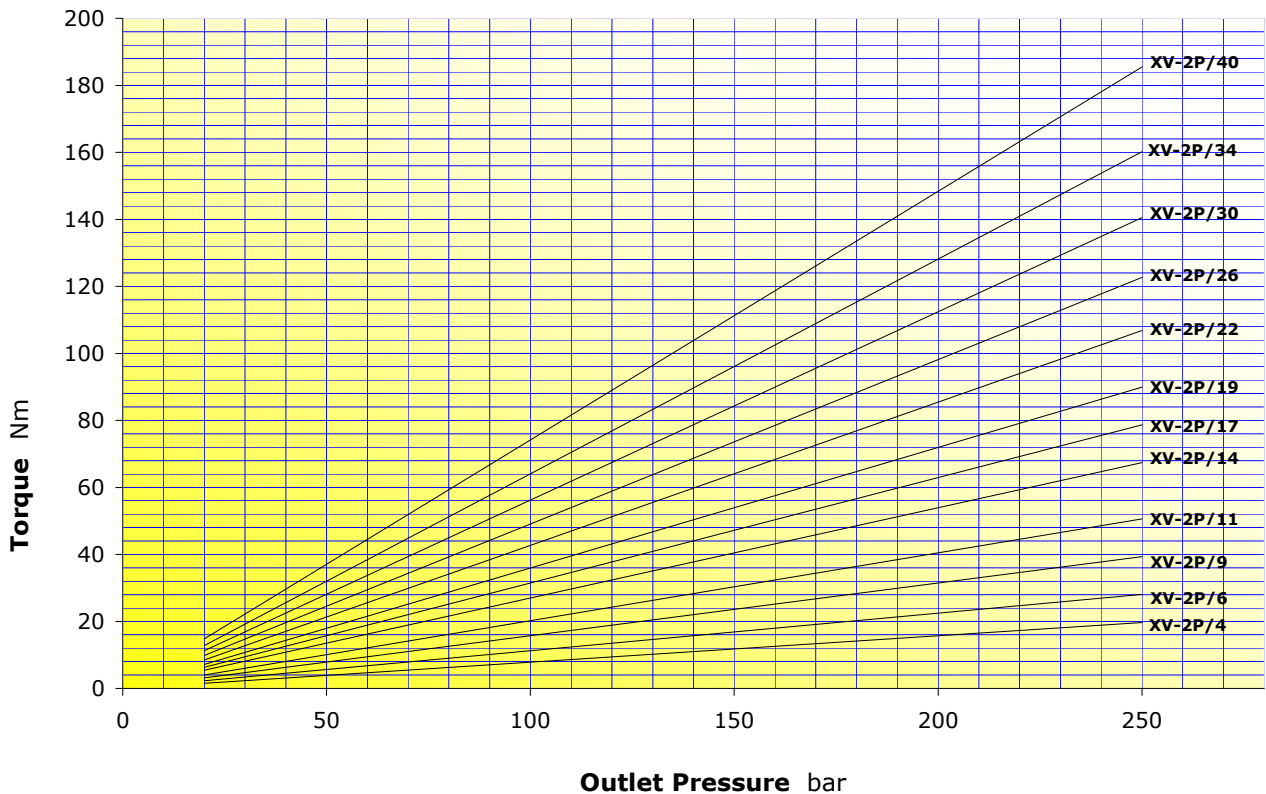

**XV-3P CHARACTERISTIC FLOW RATE CURVES**

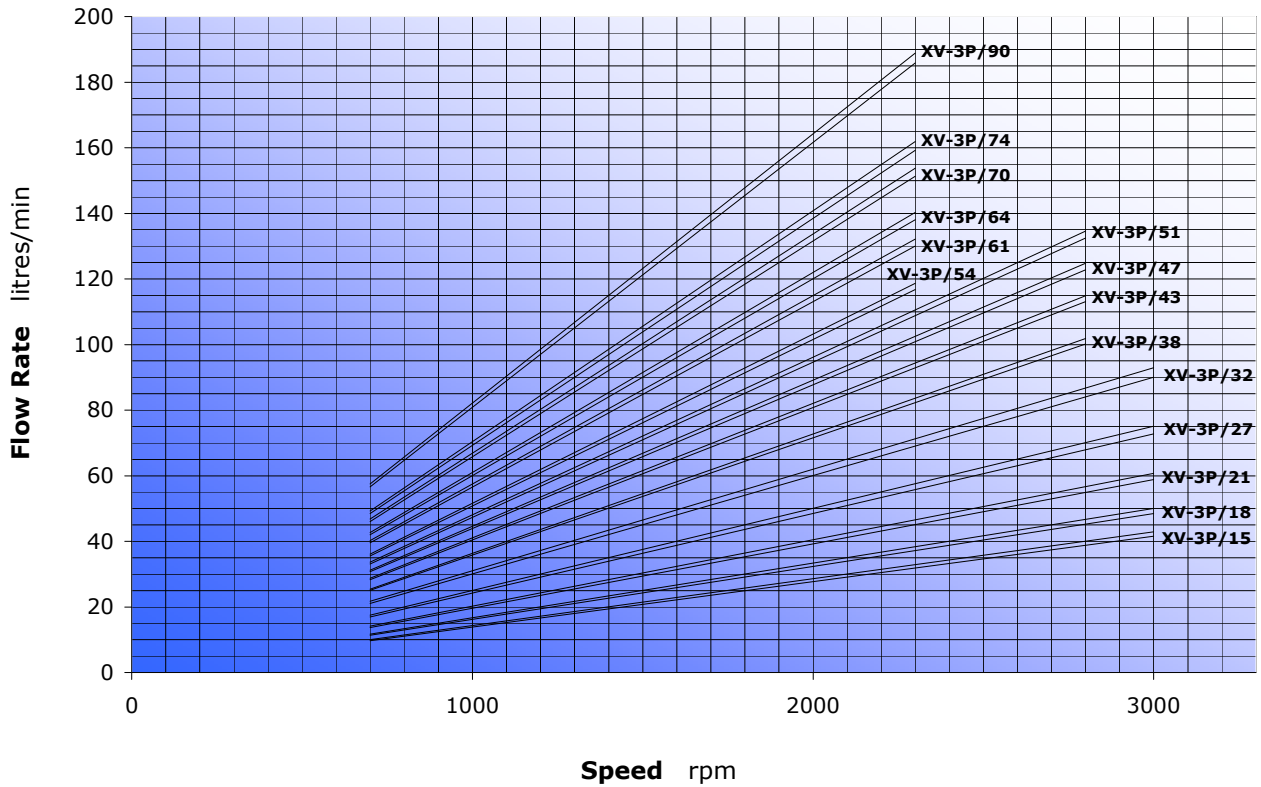

**XV-3P MOTOR TORQUE**

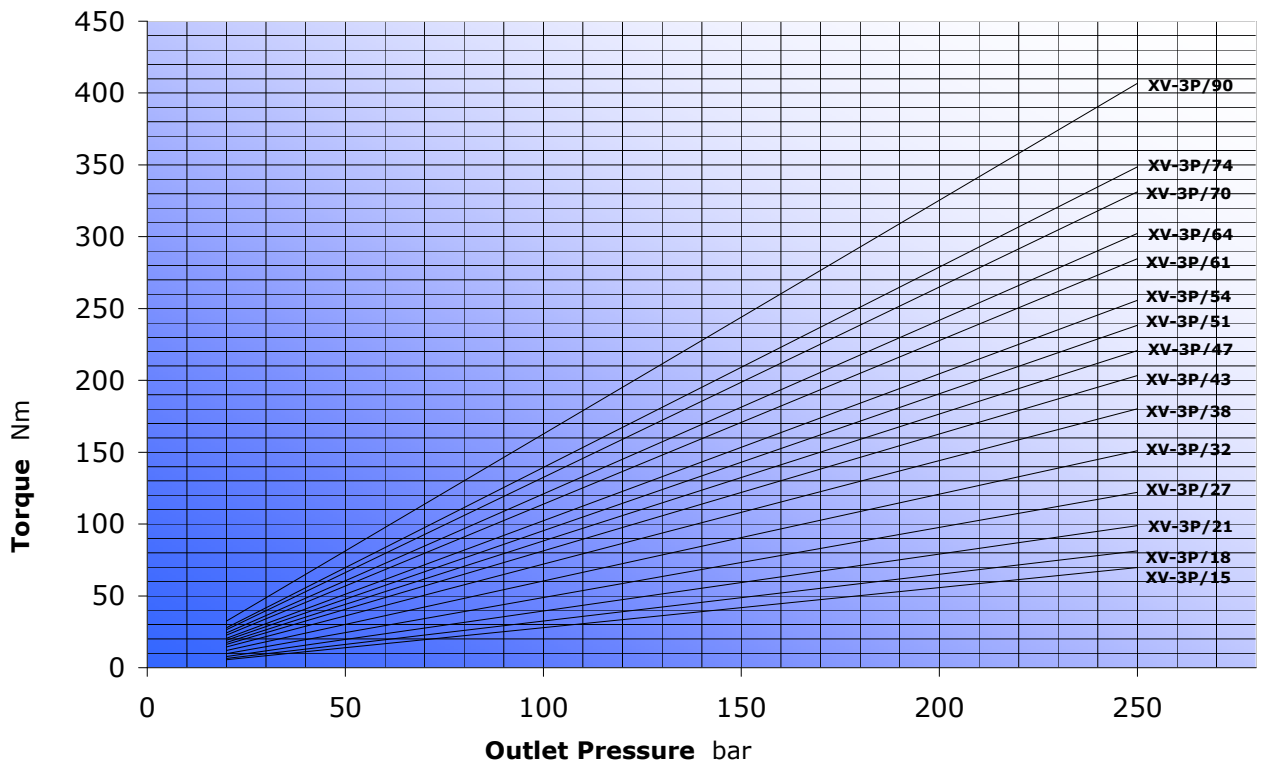

# unidirectional pump - series XV

**XV-1P**

**STANDARD EUROPEAN PUMP**  
**Ø25.4 FLANGE - TAPER SHAFT**

**X 1 P 25 02 F I I A**

Series	X	series XV
Group	1	group 1
Category	P	unidirectional pump
Displacement	25	3.8
Flange	02	Ø25.4 STANDARD EUROPEAN right rotation
Shaft	F	CO001 - Tapered 1:8 - Ø10 - M7x1 - key thk.2.4
Body	IN	inlet - Ø30 Ø12 M6
	OUT	outlet - Ø30 Ø12 M6
Cover	A	standard

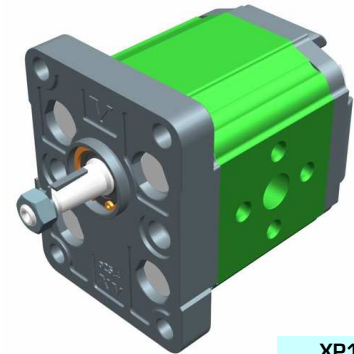

**XP101**

### Technical data table

TYPE	Displacement cm3/rev	Max. Pressure		CODE	
		P1 bar	P3 bar	Left rotation	Right rotation
XV-1P/0.9	0,91	240	280	X 1 P 16 01 F I I A	X 1 P 16 02 F I I A
XV-1P/1.2	1,17	250	290	X 1 P 17 01 F I I A	X 1 P 17 02 F I I A
XV-1P/1.7	1,56	250	290	X 1 P 18 01 F I I A	X 1 P 18 02 F I I A
XV-1P/2.2	2,08	250	290	X 1 P 20 01 F I I A	X 1 P 20 02 F I I A
XV-1P/2.6	2,60	250	300	X 1 P 21 01 F I I A	X 1 P 21 02 F I I A
XV-1P/3.2	3,12	250	300	X 1 P 23 01 F I I A	X 1 P 23 02 F I I A
XV-1P/3.8	3,64	250	300	X 1 P 25 01 F I I A	X 1 P 25 02 F I I A
XV-1P/4.3	4,16	250	300	X 1 P 27 01 F I I A	X 1 P 27 02 F I I A
XV-1P/4.9	4,94	250	300	X 1 P 29 01 F I I A	X 1 P 29 02 F I I A
XV-1P/5.9	5,85	250	300	X 1 P 31 01 F I I A	X 1 P 31 02 F I I A
XV-1P/6.5	6,50	250	300	X 1 P 32 01 F I I A	X 1 P 32 02 F I I A
XV-1P/7.8	7,54	220	260	X 1 P 34 01 F I I A	X 1 P 34 02 F I I A
XV-1P/9.8	9,88	190	230	X 1 P 36 01 F I I A	X 1 P 36 02 F I I A

P1) Max. working pressure - P3) Max. peak pressure

For heavy-duty applications, it is recommended to check the admissible torque of the shaft

### Dimensions table

TYPE	Weight kg	A	B	C	D	E	F	D	E	F
		mm	mm	mm	IN	IN	IN	IN	IN	IN
XV-1P/0.9	0,950	78,1	37,3	66,1	Ø12	30	M6x1	Ø12	30	M6x1
XV-1P/1.2	0,970	79,0	37,8	67,0	Ø12	30	M6x1	Ø12	30	M6x1
XV-1P/1.7	1,010	80,5	38,5	68,5	Ø12	30	M6x1	Ø12	30	M6x1
XV-1P/2.2	1,030	82,5	39,5	70,5	Ø12	30	M6x1	Ø12	30	M6x1
XV-1P/2.6	1,060	84,5	40,5	72,5	Ø12	30	M6x1	Ø12	30	M6x1
XV-1P/3.2	1,090	86,5	41,5	74,5	Ø12	30	M6x1	Ø12	30	M6x1
XV-1P/3.8	1,120	88,5	42,5	76,5	Ø12	30	M6x1	Ø12	30	M6x1
XV-1P/4.3	1,170	90,5	43,5	78,5	Ø12	30	M6x1	Ø12	30	M6x1
XV-1P/4.9	1,200	93,5	45,0	81,5	Ø12	30	M6x1	Ø12	30	M6x1
XV-1P/5.9	1,260	97,0	46,8	85,0	Ø12	30	M6x1	Ø12	30	M6x1
XV-1P/6.5	1,300	98,5	48,0	86,5	Ø12	30	M6x1	Ø12	30	M6x1
XV-1P/7.8	1,360	103,5	50,0	91,5	Ø12	30	M6x1	Ø12	30	M6x1
XV-1P/9.8	1,500	112,5	54,5	100,5	Ø12	30	M6x1	Ø12	30	M6x1

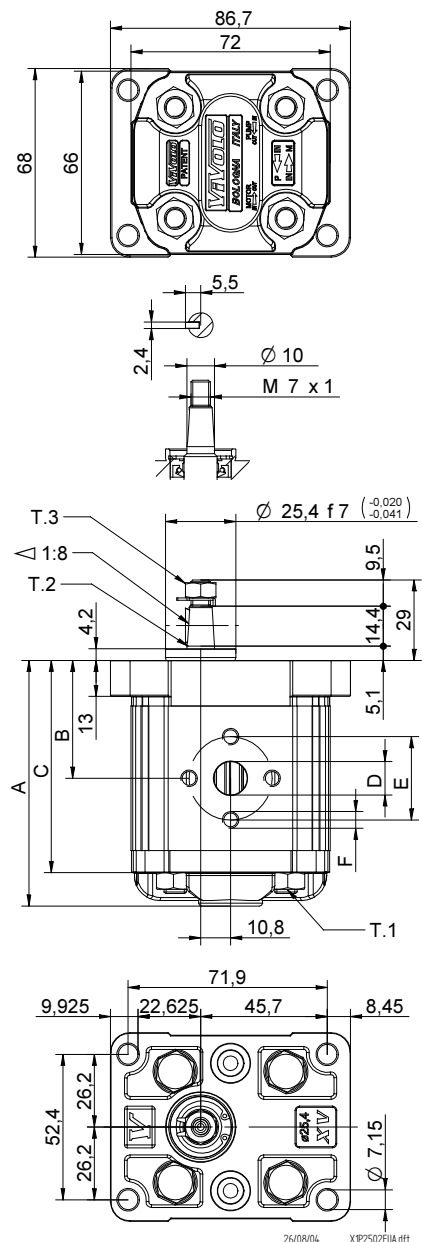

T.1 = 24.5÷29.4 [Nm] - screw tightening torque M8

T.3 = 11.5 [Nm] - torque wrench setting 11

T.2 = 43 [Nm] - admissible shaft torque (N.B. When choosing a shaft, always check the admissible torque).

# Table of variations

**XV-1P**

## ø25.4 FLANGE

ø25.4 FLANGE				Shaft				Cover			
Left rotation		Right rotation						Left rotation		Right rotation	
	<b>01</b>		<b>02</b>	CO001 - Tapered T.2 = 43 [Nm]		CF002 - Milled shank T.2 = 13.8 [Nm]					
	<b>03</b>		<b>04</b>	SCF04 - Splined T.2 = 22.6 [Nm] m=1.6 Z=6 DIN 5482 - 12x9		SCF02 - Splined T.2 = 42.8 [Nm] m=0.75 Z=15					
	<b>05</b>		<b>06</b>	SCF01 - Splined T.2 = 42.8 [Nm] m=0.75 Z=15		SCF03 - Splined T.2 = 42.8 [Nm] m=0.75 Z=15					
	<b>07</b>		<b>08</b>								

Displacement	
TYPE	CODE
XV-1P/0.9	<b>16</b>
XV-1P/1.2	<b>17</b>
XV-1P/1.7	<b>18</b>
XV-1P/2.2	<b>20</b>
XV-1P/2.6	<b>21</b>
XV-1P/3.2	<b>23</b>
XV-1P/3.8	<b>25</b>
XV-1P/4.3	<b>27</b>
XV-1P/4.9	<b>29</b>
XV-1P/5.9	<b>31</b>
XV-1P/6.5	<b>32</b>
XV-1P/7.8	<b>34</b>
XV-1P/9.8	<b>36</b>

Standard bodies							
Displacement cm3/rev	Standard threads						
	0.9	I - I	B - B	J - J	B - Z	Z - Z	G - F
1.2	I - I	B - B	J - J	B - Z	Z - Z	G - F	
1.7	I - I	B - B	J - J	B - Z	Z - Z	G - F	
2.2	I - I	B - B	J - J	B - Z	Z - Z	G - F	
2.6	I - I	B - B	J - J	B - Z	Z - Z	G - F	
3.2	I - I	B - B	J - J	B - Z	Z - Z	G - F	
3.8	I - I	B - B	J - J	B - Z	Z - Z	G - F	
4.3	I - I	B - B	J - J	B - Z	Z - Z	G - F	
4.9	I - I	B - B	J - J	B - Z	Z - Z	G - F	
5.9	I - I	B - B	J - J	B - Z	Z - Z	G - F	
6.5	I - I	B - B	J - J	B - Z	Z - Z	G - F	
7.8	I - I	B - B	J - J	B - Z	Z - Z	G - F	
9.8	I - I	B - B	J - J	B - Z	Z - Z	G - F	

Table showing standard flange and thread combinations available in stock

		<b>N</b>
Internal drainage		
		<b>O</b>
External drainage		

Body (threads/flanges)							
	<b>A</b>		<b>B</b>		<b>C</b>		<b>D</b>
	<b>E</b>		<b>F</b>		<b>G</b>		
	<b>H</b>		<b>I</b>		<b>J</b>	<b>Closed Body</b>	<b>Z</b>

# unidirectional pump - series XV

**XV-1P**

**STANDARD EUROPEAN PUMP**  
**ø25.4 FLANGE - TAPER SHAFT**

**X 1 P 25 02 F B B A**

Series	X	series XV
Group	1	group 1
Category	P	unidirectional pump
Displacement	25	3.8
Flange	02	Ø25.4 STANDARD EUROPEAN right rotation
Shaft	F	CO001 - Tapered 1:8 - ø10 - M7x1 - key thk.2.4
Body	IN	inlet - 3/8" GAS
	OUT	outlet - 3/8" GAS
Cover	A	standard

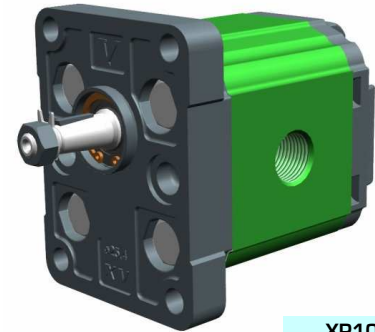

**XP105**

**Technical data table**

TYPE	Displacement cm3/rev	Max. Pressure		CODE			
		P1 bar	P3 bar	Left rotation		Right rotation	
XV-1P/0.9	0,91	240	280	X 1 P 16 01	F B B A	X 1 P 16 02	F B B A
XV-1P/1.2	1,17	250	290	X 1 P 17 01	F B B A	X 1 P 17 02	F B B A
XV-1P/1.7	1,56	250	290	X 1 P 18 01	F B B A	X 1 P 18 02	F B B A
XV-1P/2.2	2,08	250	290	X 1 P 20 01	F B B A	X 1 P 20 02	F B B A
XV-1P/2.6	2,60	250	300	X 1 P 21 01	F B B A	X 1 P 21 02	F B B A
XV-1P/3.2	3,12	250	300	X 1 P 23 01	F B B A	X 1 P 23 02	F B B A
XV-1P/3.8	3,64	250	300	X 1 P 25 01	F B B A	X 1 P 25 02	F B B A
XV-1P/4.3	4,16	250	300	X 1 P 27 01	F B B A	X 1 P 27 02	F B B A
XV-1P/4.9	4,94	250	300	X 1 P 29 01	F B B A	X 1 P 29 02	F B B A
XV-1P/5.9	5,85	250	300	X 1 P 31 01	F B B A	X 1 P 31 02	F B B A
XV-1P/6.5	6,50	250	300	X 1 P 32 01	F B B A	X 1 P 32 02	F B B A
XV-1P/7.8	7,54	220	260	X 1 P 34 01	F B B A	X 1 P 34 02	F B B A
XV-1P/9.8	9,88	190	230	X 1 P 36 01	F B B A	X 1 P 36 02	F B B A

P1) Max. working pressure - P3) Max. peak pressure

For heavy-duty applications, it is recommended to check the admissible torque of the shaft

**Dimensions table**

TYPE	Weight kg	A	B	C	D	
		mm	mm	mm	IN	OUT
XV-1P/0.9	0,950	78,1	37,3	66,1	3/8" BSPP	3/8" BSPP
XV-1P/1.2	0,970	79,0	37,8	67,0	3/8" BSPP	3/8" BSPP
XV-1P/1.7	1,010	80,5	38,5	68,5	3/8" BSPP	3/8" BSPP
XV-1P/2.2	1,030	82,5	39,5	70,5	3/8" BSPP	3/8" BSPP
XV-1P/2.6	1,060	84,5	40,5	72,5	3/8" BSPP	3/8" BSPP
XV-1P/3.2	1,090	86,5	41,5	74,5	3/8" BSPP	3/8" BSPP
XV-1P/3.8	1,120	88,5	42,5	76,5	3/8" BSPP	3/8" BSPP
XV-1P/4.3	1,170	90,5	43,5	78,5	3/8" BSPP	3/8" BSPP
XV-1P/4.9	1,200	93,5	45,0	81,5	3/8" BSPP	3/8" BSPP
XV-1P/5.9	1,260	97,0	46,8	85,0	3/8" BSPP	3/8" BSPP
XV-1P/6.5	1,300	98,5	48,0	86,5	3/8" BSPP	3/8" BSPP
XV-1P/7.8	1,360	103,5	50,0	91,5	3/8" BSPP	3/8" BSPP
XV-1P/9.8	1,500	112,5	54,5	100,5	3/8" BSPP	3/8" BSPP

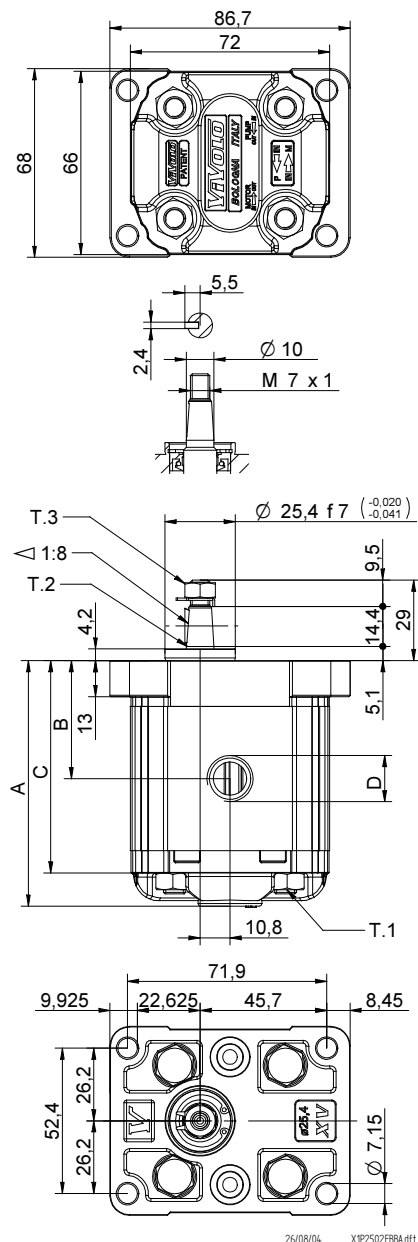

26/08/04 XV1P2502FBBAdff

T.1 = 24.5÷29.4 [Nm] - screw tightening torque M8

T.3 = 11.5 [Nm] - torque wrench setting 11

T.2 = 43 [Nm] - admissible shaft torque (N.B. When choosing a shaft, always check the admissible torque).

# Table of variations

**XV-1P**

## ø25.4 FLANGE

ø25.4 FLANGE				Shaft				Cover			
Left rotation		Right rotation						Left rotation		Right rotation	
	<b>01</b>		<b>02</b>	<b>CO001 - Tapered</b> T.2 = 43 [Nm] 	<b>F</b>	<b>CF002 - Milled shank</b> T.2 = 13.8 [Nm] 	<b>D</b>				<b>A</b>
	<b>03</b>		<b>04</b>	<b>SCF04 - Splined</b> T.2 = 22.6 [Nm] m=1.6 Z=6 DIN 5482 - 12x9 	<b>J</b>	<b>SCF02 - Splined</b> T.2 = 42.8 [Nm] m=0.75 Z=15 	<b>L</b>				<b>B</b>
	<b>05</b>		<b>06</b>	<b>SCF01 - Splined</b> T.2 = 42.8 [Nm] m=0.75 Z=15 	<b>Q</b>	<b>SCF03 - Splined</b> T.2 = 42.8 [Nm] m=0.75 Z=15 	<b>R</b>				<b>C</b>
	<b>07</b>		<b>08</b>								<b>D</b>

Displacement	
TYPE	CODE
XV-1P/0.9	<b>16</b>
XV-1P/1.2	<b>17</b>
XV-1P/1.7	<b>18</b>
XV-1P/2.2	<b>20</b>
XV-1P/2.6	<b>21</b>
XV-1P/3.2	<b>23</b>
XV-1P/3.8	<b>25</b>
XV-1P/4.3	<b>27</b>
XV-1P/4.9	<b>29</b>
XV-1P/5.9	<b>31</b>
XV-1P/6.5	<b>32</b>
XV-1P/7.8	<b>34</b>
XV-1P/9.8	<b>36</b>

Standard bodies							
Displacement cm3/rev	Standard threads						
	0.9	I - I	B - B	J - J	B - Z	Z - Z	G - F
1.2	I - I	B - B	J - J	B - Z	Z - Z	G - F	
1.7	I - I	B - B	J - J	B - Z	Z - Z	G - F	
2.2	I - I	B - B	J - J	B - Z	Z - Z	G - F	
2.6	I - I	B - B	J - J	B - Z	Z - Z	G - F	
3.2	I - I	B - B	J - J	B - Z	Z - Z	G - F	
3.8	I - I	B - B	J - J	B - Z	Z - Z	G - F	
4.3	I - I	B - B	J - J	B - Z	Z - Z	G - F	
4.9	I - I	B - B	J - J	B - Z	Z - Z	G - F	
5.9	I - I	B - B	J - J	B - Z	Z - Z	G - F	
6.5	I - I	B - B	J - J	B - Z	Z - Z	G - F	
7.8	I - I	B - B	J - J	B - Z	Z - Z	G - F	
9.8	I - I	B - B	J - J	B - Z	Z - Z	G - F	

Table showing standard flange and thread combinations available in stock

		<b>N</b>
Internal drainage		
		<b>O</b>
External drainage		

Body (threads/flanges)							
	<b>A</b>		<b>B</b>		<b>C</b>		<b>D</b>
	<b>E</b>		<b>F</b>		<b>G</b>		
	<b>H</b>		<b>I</b>		<b>J</b>	<b>Closed Body</b>	<b>Z</b>

# unidirectional pump - series XV

**XV-1P**

**STANDARD PUMP**  
**ø30 FLANGE - TAPER SHAFT**

**X 1 P 25 12 G I I A**

Series	X	series XV
Group	1	group 1
Category	P	unidirectional pump
Displacement	25	3.8
Flange	12	Ø30 STANDARD right rotation
Shaft	G	CO002 - Tapered 1:8 - ø14 - M10x1 - key thk.3
Body	IN	inlet - Ø30 Ø12 M6
	OUT	outlet - Ø30 Ø12 M6
Cover	A	standard

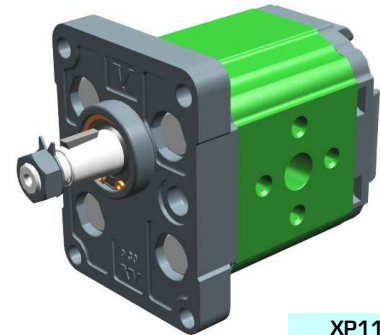

**XP113**

**Technical data table**

TYPE	Displacement cm3/rev	Max. Pressure		CODE	
		P1 bar	P3 bar	Left rotation	Right rotation
XV-1P/0.9	0,91	240	280	X 1 P 16 11 G I I A	X 1 P 16 12 G I I A
XV-1P/1.2	1,17	250	290	X 1 P 17 11 G I I A	X 1 P 17 12 G I I A
XV-1P/1.7	1,56	250	290	X 1 P 18 11 G I I A	X 1 P 18 12 G I I A
XV-1P/2.2	2,08	250	290	X 1 P 20 11 G I I A	X 1 P 20 12 G I I A
XV-1P/2.6	2,60	250	300	X 1 P 21 11 G I I A	X 1 P 21 12 G I I A
XV-1P/3.2	3,12	250	300	X 1 P 23 11 G I I A	X 1 P 23 12 G I I A
XV-1P/3.8	3,64	250	300	X 1 P 25 11 G I I A	X 1 P 25 12 G I I A
XV-1P/4.3	4,16	250	300	X 1 P 27 11 G I I A	X 1 P 27 12 G I I A
XV-1P/4.9	4,94	250	300	X 1 P 29 11 G I I A	X 1 P 29 12 G I I A
XV-1P/5.9	5,85	250	300	X 1 P 31 11 G I I A	X 1 P 31 12 G I I A
XV-1P/6.5	6,50	250	300	X 1 P 32 11 G I I A	X 1 P 32 12 G I I A
XV-1P/7.8	7,54	220	260	X 1 P 34 11 G I I A	X 1 P 34 12 G I I A
XV-1P/9.8	9,88	190	230	X 1 P 36 11 G I I A	X 1 P 36 12 G I I A

P1) Max. working pressure - P3) Max. peak pressure

For heavy-duty applications, it is recommended to check the admissible torque of the shaft

**Dimensions table**

TYPE	Weight kg	A	B	C	D	E	F	D	E	F
		mm	mm	mm	IN	IN	IN	OUT	OUT	OUT
XV-1P/0.9	0,950	78,1	37,3	66,1	ø12	30	M6x1	ø12	30	M6x1
XV-1P/1.2	0,970	79,0	37,8	67,0	ø12	30	M6x1	ø12	30	M6x1
XV-1P/1.7	1,010	80,5	38,5	68,5	ø12	30	M6x1	ø12	30	M6x1
XV-1P/2.2	1,030	82,5	39,5	70,5	ø12	30	M6x1	ø12	30	M6x1
XV-1P/2.6	1,060	84,5	40,5	72,5	ø12	30	M6x1	ø12	30	M6x1
XV-1P/3.2	1,090	86,5	41,5	74,5	ø12	30	M6x1	ø12	30	M6x1
XV-1P/3.8	1,120	88,5	42,5	76,5	ø12	30	M6x1	ø12	30	M6x1
XV-1P/4.3	1,170	90,5	43,5	78,5	ø12	30	M6x1	ø12	30	M6x1
XV-1P/4.9	1,200	93,5	45,0	81,5	ø12	30	M6x1	ø12	30	M6x1
XV-1P/5.9	1,260	97,0	46,8	85,0	ø12	30	M6x1	ø12	30	M6x1
XV-1P/6.5	1,300	98,5	48,0	86,5	ø12	30	M6x1	ø12	30	M6x1
XV-1P/7.8	1,360	103,5	50,0	91,5	ø12	30	M6x1	ø12	30	M6x1
XV-1P/9.8	1,500	112,5	54,5	100,5	ø12	30	M6x1	ø12	30	M6x1

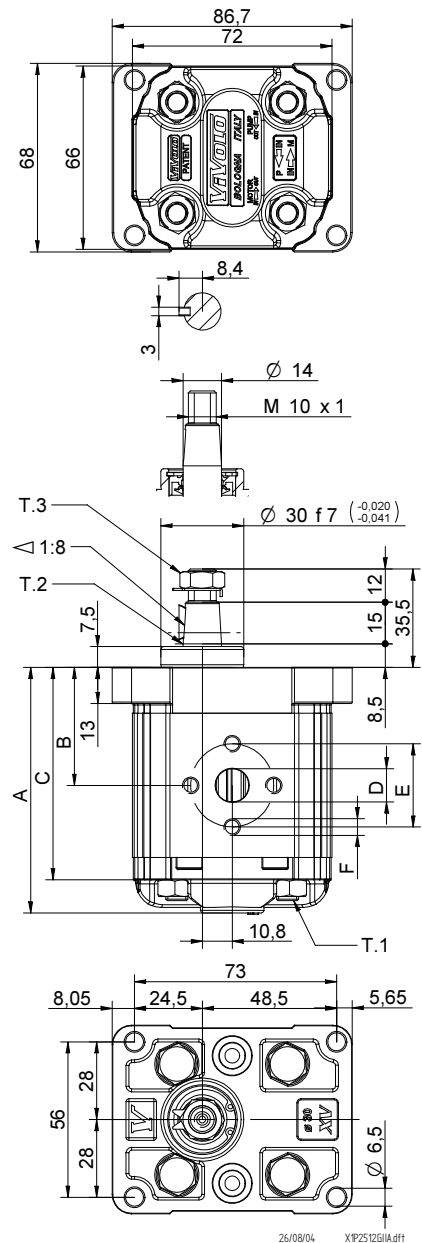

T.1 = 24.5÷29.4 [Nm] - screw tightening torque M8

T.3 = 13 [Nm] - torque wrench setting 17

T.2 = 119.8 [Nm] - admissible shaft torque (N.B. When choosing a shaft, always check the admissible torque).



# Table of variations

**XV-1P**

## ø30 FLANGE

ø30 FLANGE				Shaft				Cover			
Left rotation		Right rotation						Left rotation		Right rotation	
	<b>11</b>		<b>12</b>	CI001 - Parallel T.2 = 25.8 [Nm]	<b>A</b>	CO002 - Tapered T.2 = 119.8 [Nm]	<b>G</b>				<b>A</b>
	<b>13</b>		<b>14</b>	CI001+HK - Parallel T.2 = 25.8 [Nm]	<b>P</b>	CO002+HK - Tapered T.2 = 119.8 [Nm]	<b>O</b>				<b>B</b>
	<b>15</b>		<b>16</b>								<b>C</b>
	<b>17</b>		<b>18</b>								<b>D</b>

Displacement	
TYPE	CODE
XV-1P/0.9	<b>16</b>
XV-1P/1.2	<b>17</b>
XV-1P/1.7	<b>18</b>
XV-1P/2.2	<b>20</b>
XV-1P/2.6	<b>21</b>
XV-1P/3.2	<b>23</b>
XV-1P/3.8	<b>25</b>
XV-1P/4.3	<b>27</b>
XV-1P/4.9	<b>29</b>
XV-1P/5.9	<b>31</b>
XV-1P/6.5	<b>32</b>
XV-1P/7.8	<b>34</b>
XV-1P/9.8	<b>36</b>

Standard bodies							
Displacement cm3/rev	Standard threads						
	0.9	I-I	B-B	J-J	B-Z	Z-Z	G-F
1.2	I-I	B-B	J-J	B-Z	Z-Z	G-F	
1.7	I-I	B-B	J-J	B-Z	Z-Z	G-F	
2.2	I-I	B-B	J-J	B-Z	Z-Z	G-F	
2.6	I-I	B-B	J-J	B-Z	Z-Z	G-F	
3.2	I-I	B-B	J-J	B-Z	Z-Z	G-F	
3.8	I-I	B-B	J-J	B-Z	Z-Z	G-F	
4.3	I-I	B-B	J-J	B-Z	Z-Z	G-F	
4.9	I-I	B-B	J-J	B-Z	Z-Z	G-F	
5.9	I-I	B-B	J-J	B-Z	Z-Z	G-F	
6.5	I-I	B-B	J-J	B-Z	Z-Z	G-F	
7.8	I-I	B-B	J-J	B-Z	Z-Z	G-F	
9.8	I-I	B-B	J-J	B-Z	Z-Z	G-F	

Table showing standard flange and thread combinations available in stock

	<b>N</b>
	<b>O</b>

Body (threads/flanges)							
	<b>A</b>		<b>B</b>		<b>C</b>		<b>D</b>
	<b>E</b>		<b>F</b>		<b>G</b>		
	<b>H</b>		<b>I</b>		<b>J</b>	<b>Closed Body</b>	<b>Z</b>

# unidirectional pump - series XV

**XV-1P**

"BH" TYPE PUMP  
 ø32 BODY-SHAPED FLANGE - MILLED SHANK

**X 1 P 25 42 D B B A**

Series	X	series XV
Group	1	group 1
Category	P	unidirectional pump
Displacement	25	3.8
Flange	42	Ø32 BH right rotation
Shaft	D	CF002 - Milled shank ø10 - thk.5
Body	IN	inlet - 3/8" GAS
	OUT	outlet - 3/8" GAS
Cover	A	standard



XP119

### Technical data table

TYPE	Displacement cm3/rev	Max. Pressure		CODE			
		P1 bar	P3 bar	Left rotation		Right rotation	
XV-1P/0.9	0,91	240	280	X 1 P 16 41	D B B A	X 1 P 16 42	D B B A
XV-1P/1.2	1,17	250	290	X 1 P 17 41	D B B A	X 1 P 17 42	D B B A
XV-1P/1.7	1,56	250	290	X 1 P 18 41	D B B A	X 1 P 18 42	D B B A
XV-1P/2.2	2,08	250	290	X 1 P 20 41	D B B A	X 1 P 20 42	D B B A
XV-1P/2.6	2,60	250	300	X 1 P 21 41	D B B A	X 1 P 21 42	D B B A
XV-1P/3.2	3,12	250	300	X 1 P 23 41	D B B A	X 1 P 23 42	D B B A
XV-1P/3.8	3,64	250	300	X 1 P 25 41	D B B A	X 1 P 25 42	D B B A
XV-1P/4.3	4,16	250	300	X 1 P 27 41	D B B A	X 1 P 27 42	D B B A
XV-1P/4.9	4,94	250	300	X 1 P 29 41	D B B A	X 1 P 29 42	D B B A
XV-1P/5.9	5,85	250	300	X 1 P 31 41	D B B A	X 1 P 31 42	D B B A
XV-1P/6.5	6,50	250	300	X 1 P 32 41	D B B A	X 1 P 32 42	D B B A
XV-1P/7.8	7,54	220	260	X 1 P 34 41	D B B A	X 1 P 34 42	D B B A
XV-1P/9.8	9,88	190	230	X 1 P 36 41	D B B A	X 1 P 36 42	D B B A

P1) Max. working pressure - P3) Max. peak pressure

For heavy-duty applications, it is recommended to check the admissible torque of the shaft

### Dimensions table

TYPE	Weight kg	A	B	C	D	
		mm	mm	mm	IN	OUT
XV-1P/0.9	0,950	77,1	36,3	65,1	3/8" BSPP	3/8" BSPP
XV-1P/1.2	0,970	78,0	36,8	66,0	3/8" BSPP	3/8" BSPP
XV-1P/1.7	1,010	79,5	37,5	67,5	3/8" BSPP	3/8" BSPP
XV-1P/2.2	1,030	81,5	38,5	69,5	3/8" BSPP	3/8" BSPP
XV-1P/2.6	1,060	83,5	39,5	71,5	3/8" BSPP	3/8" BSPP
XV-1P/3.2	1,090	85,5	40,5	73,5	3/8" BSPP	3/8" BSPP
XV-1P/3.8	1,120	87,5	41,5	75,5	3/8" BSPP	3/8" BSPP
XV-1P/4.3	1,170	89,5	42,5	77,5	3/8" BSPP	3/8" BSPP
XV-1P/4.9	1,200	92,5	44,0	80,5	3/8" BSPP	3/8" BSPP
XV-1P/5.9	1,260	96,0	45,8	84,0	3/8" BSPP	3/8" BSPP
XV-1P/6.5	1,300	97,5	47,0	85,5	3/8" BSPP	3/8" BSPP
XV-1P/7.8	1,360	102,5	49,0	90,5	3/8" BSPP	3/8" BSPP
XV-1P/9.8	1,500	111,5	53,5	99,5	3/8" BSPP	3/8" BSPP

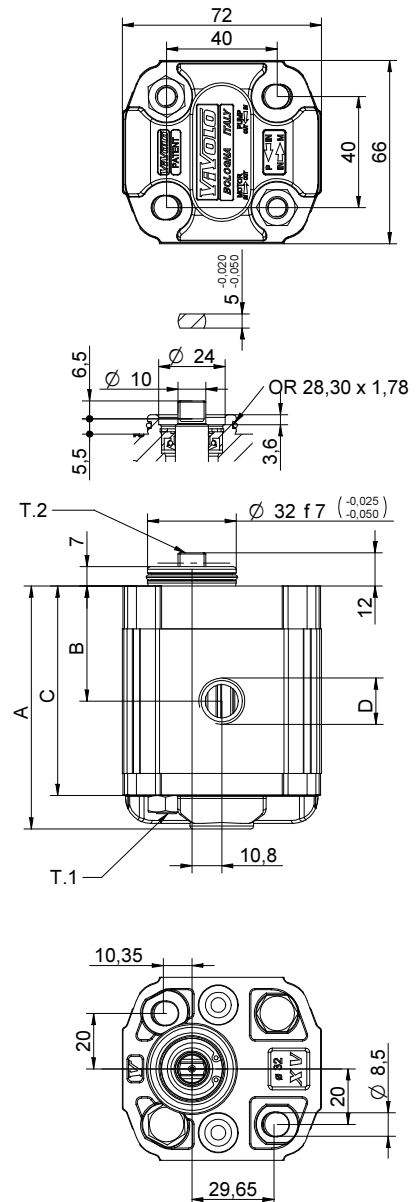

26/08/04 XP254,2DBBA.dft

T.1 = 24.5÷29.4 [Nm] - screw tightening torque M8

T.2 = 13.8 [Nm] - admissible shaft torque (N.B. When choosing a shaft, always check the admissible torque).

# Table of variations

**XV-1P**

## ø32 "BH" Body-Shaped FLANGE

ø32 "BH" Body-Shaped FLANGE				Shaft				Cover			
Left rotation		Right rotation						Left rotation		Right rotation	
	41		42	CF002 - Milled shank T.2 = 13.8 [Nm]	D	CO001 - Tapered T.2 = 43 [Nm]	F				A
	43		44	SCF02 - Splined T.2 = 42.8 [Nm] m=0,75 Z=15	L	SCF04 - Splined T.2 = 22.6 [Nm] m=1,6 Z=6 DIN 5482 - 12x9	J				B
	45		46	SCF01 - Splined T.2 = 42.8 [Nm] m=0,75 Z=15	Q	SCF03 - Splined T.2 = 42.8 [Nm] m=0,75 Z=15	R				C
	47		48								D

Displacement	
TYPE	CODE
XV-1P/0.9	16
XV-1P/1.2	17
XV-1P/1.7	18
XV-1P/2.2	20
XV-1P/2.6	21
XV-1P/3.2	23
XV-1P/3.8	25
XV-1P/4.3	27
XV-1P/4.9	29
XV-1P/5.9	31
XV-1P/6.5	32
XV-1P/7.8	34
XV-1P/9.8	36

Standard bodies							
Displacement cm3/rev	Standard threads						
	0.9	I - I	B - B	J - J	B - Z	Z - Z	G - F
1.2	I - I	B - B	J - J	B - Z	Z - Z	G - F	
1.7	I - I	B - B	J - J	B - Z	Z - Z	G - F	
2.2	I - I	B - B	J - J	B - Z	Z - Z	G - F	
2.6	I - I	B - B	J - J	B - Z	Z - Z	G - F	
3.2	I - I	B - B	J - J	B - Z	Z - Z	G - F	
3.8	I - I	B - B	J - J	B - Z	Z - Z	G - F	
4.3	I - I	B - B	J - J	B - Z	Z - Z	G - F	
4.9	I - I	B - B	J - J	B - Z	Z - Z	G - F	
5.9	I - I	B - B	J - J	B - Z	Z - Z	G - F	
6.5	I - I	B - B	J - J	B - Z	Z - Z	G - F	
7.8	I - I	B - B	J - J	B - Z	Z - Z	G - F	
9.8	I - I	B - B	J - J	B - Z	Z - Z	G - F	

Table showing standard flange and thread combinations available in stock

				N
Internal drainage				
				O
External drainage				

Body (threads/flanges)													
	A		B		C		D		E		F		G
	H		I		J		Z	Closed Body					

# unidirectional pump - series XV

**XV-1P**

"HY" TYPE PUMP  
 ø32 BODY-SHAPED FLANGE - MILLED SHANK

**X 1 P 25 52 D B B A**

Series	X	series XV
Group	1	group 1
Category	P	unidirectional pump
Displacement	25	3.8
Flange	52	Ø32 HY right rotation
Shaft	D	CF002 - Milled shank ø10 - thk.5
Body	IN	inlet - 3/8" GAS
	OUT	outlet - 3/8" GAS
Cover	A	standard



XP140

### Technical data table

TYPE	Displacement cm3/rev	Max. Pressure		CODE			
		P1 bar	P3 bar	Left rotation		Right rotation	
XV-1P/0.9	0,91	240	280	X 1 P 16 51	D B B A	X 1 P 16 52	D B B A
XV-1P/1.2	1,17	250	290	X 1 P 17 51	D B B A	X 1 P 17 52	D B B A
XV-1P/1.7	1,56	250	290	X 1 P 18 51	D B B A	X 1 P 18 52	D B B A
XV-1P/2.2	2,08	250	290	X 1 P 20 51	D B B A	X 1 P 20 52	D B B A
XV-1P/2.6	2,60	250	300	X 1 P 21 51	D B B A	X 1 P 21 52	D B B A
XV-1P/3.2	3,12	250	300	X 1 P 23 51	D B B A	X 1 P 23 52	D B B A
XV-1P/3.8	3,64	250	300	X 1 P 25 51	D B B A	X 1 P 25 52	D B B A
XV-1P/4.3	4,16	250	300	X 1 P 27 51	D B B A	X 1 P 27 52	D B B A
XV-1P/4.9	4,94	250	300	X 1 P 29 51	D B B A	X 1 P 29 52	D B B A
XV-1P/5.9	5,85	250	300	X 1 P 31 51	D B B A	X 1 P 31 52	D B B A
XV-1P/6.5	6,50	250	300	X 1 P 32 51	D B B A	X 1 P 32 52	D B B A
XV-1P/7.8	7,54	220	260	X 1 P 34 51	D B B A	X 1 P 34 52	D B B A
XV-1P/9.8	9,88	190	230	X 1 P 36 51	D B B A	X 1 P 36 52	D B B A

P1) Max. working pressure - P3) Max. peak pressure

For heavy-duty applications, it is recommended to check the admissible torque of the shaft

### Dimensions table

TYPE	Weight kg	A	B	C	D	D
		mm	mm	mm	IN	OUT
XV-1P/0.9	0,950	77,1	36,3	65,1	3/8" BSPP	3/8" BSPP
XV-1P/1.2	0,970	78,0	36,8	66,0	3/8" BSPP	3/8" BSPP
XV-1P/1.7	1,010	79,5	37,5	67,5	3/8" BSPP	3/8" BSPP
XV-1P/2.2	1,030	81,5	38,5	69,5	3/8" BSPP	3/8" BSPP
XV-1P/2.6	1,060	83,5	39,5	71,5	3/8" BSPP	3/8" BSPP
XV-1P/3.2	1,090	85,5	40,5	73,5	3/8" BSPP	3/8" BSPP
XV-1P/3.8	1,120	87,5	41,5	75,5	3/8" BSPP	3/8" BSPP
XV-1P/4.3	1,170	89,5	42,5	77,5	3/8" BSPP	3/8" BSPP
XV-1P/4.9	1,200	92,5	44,0	80,5	3/8" BSPP	3/8" BSPP
XV-1P/5.9	1,260	96,0	45,8	84,0	3/8" BSPP	3/8" BSPP
XV-1P/6.5	1,300	97,5	47,0	85,5	3/8" BSPP	3/8" BSPP
XV-1P/7.8	1,360	102,5	49,0	90,5	3/8" BSPP	3/8" BSPP
XV-1P/9.8	1,500	111,5	53,5	99,5	3/8" BSPP	3/8" BSPP

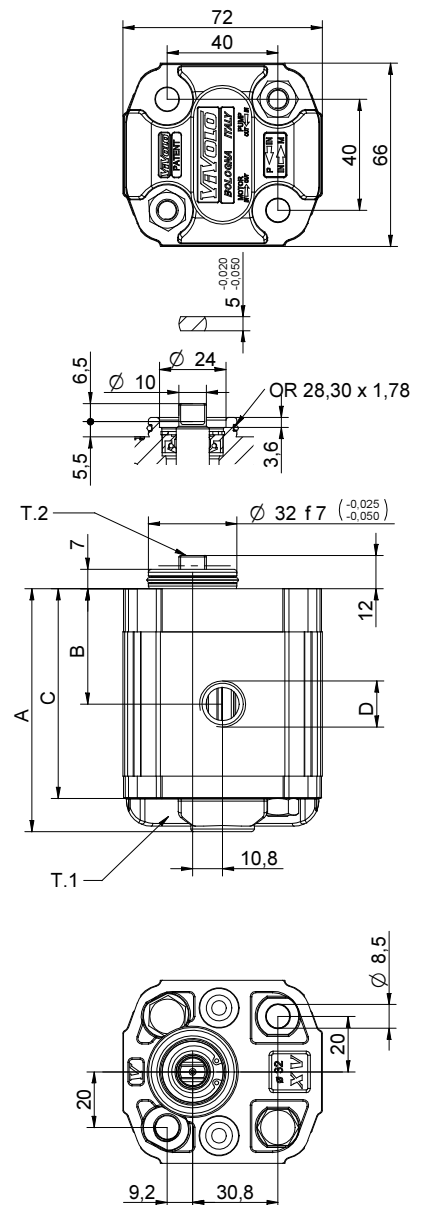

26/08/04 XP2552DBBA.dft

T.1 = 24.5÷29.4 [Nm] - screw tightening torque M8

T.2 = 13.8 [Nm] - admissible shaft torque (N.B. When choosing a shaft, always check the admissible torque).

# Table of variations

**XV-1P**

## ø32 "HY" Body-Shaped FLANGE

ø32 "HY" Body-Shaped FLANGE				Shaft				Cover			
Left rotation		Right rotation						Left rotation		Right rotation	
	<b>51</b>		<b>52</b>	CF002 - Milled shank T.2 = 13.8 [Nm] 	<b>D</b>	CO001 - Tapered T.2 = 43 [Nm] 	<b>F</b>			<b>A</b>	
	<b>53</b>		<b>54</b>	SCF02 - Splined T.2 = 42.8 [Nm] m=0,75 Z=15 	<b>L</b>	SCF04 - Splined T.2 = 22.6 [Nm] m=1,6 Z=6 DIN 5482 - 12x9 	<b>J</b>			<b>B</b>	
	<b>55</b>		<b>56</b>	SCF01 - Splined T.2 = 42.8 [Nm] m=0,75 Z=15 	<b>Q</b>	SCF03 - Splined T.2 = 42.8 [Nm] m=0,75 Z=15 	<b>R</b>			<b>C</b>	
	<b>57</b>		<b>58</b>							<b>D</b>	

Displacement	
TYPE	CODE
XV-1P/0.9	<b>16</b>
XV-1P/1.2	<b>17</b>
XV-1P/1.7	<b>18</b>
XV-1P/2.2	<b>20</b>
XV-1P/2.6	<b>21</b>
XV-1P/3.2	<b>23</b>
XV-1P/3.8	<b>25</b>
XV-1P/4.3	<b>27</b>
XV-1P/4.9	<b>29</b>
XV-1P/5.9	<b>31</b>
XV-1P/6.5	<b>32</b>
XV-1P/7.8	<b>34</b>
XV-1P/9.8	<b>36</b>

Standard bodies							
Displacement cm3/rev	Standard threads						
	0.9	I - I	B - B	J - J	B - Z	Z - Z	G - F
1.2	I - I	B - B	J - J	B - Z	Z - Z	G - F	
1.7	I - I	B - B	J - J	B - Z	Z - Z	G - F	
2.2	I - I	B - B	J - J	B - Z	Z - Z	G - F	
2.6	I - I	B - B	J - J	B - Z	Z - Z	G - F	
3.2	I - I	B - B	J - J	B - Z	Z - Z	G - F	
3.8	I - I	B - B	J - J	B - Z	Z - Z	G - F	
4.3	I - I	B - B	J - J	B - Z	Z - Z	G - F	
4.9	I - I	B - B	J - J	B - Z	Z - Z	G - F	
5.9	I - I	B - B	J - J	B - Z	Z - Z	G - F	
6.5	I - I	B - B	J - J	B - Z	Z - Z	G - F	
7.8	I - I	B - B	J - J	B - Z	Z - Z	G - F	
9.8	I - I	B - B	J - J	B - Z	Z - Z	G - F	

Table showing standard flange and thread combinations available in stock

		<b>N</b>
Internal drainage		
		<b>O</b>
External drainage		

Body (threads/flanges)													
	<b>A</b>		<b>B</b>		<b>C</b>		<b>D</b>		<b>E</b>		<b>F</b>		<b>G</b>
	<b>H</b>		<b>I</b>		<b>J</b>		<b>Z</b>	Closed Body					

# unidirectional pump - series XV

**XV-1P**

STANDARD GERMAN "BH" TYPE PUMP  
 ø32 BODY-SHAPED FLANGE - MILLED SHANK

**X 1 P 25 32 C B B A**

Series	X	series XV
Group	1	group 1
Category	P	unidirectional pump
Displacement	25	3.8
Flange	32	Ø32 BH GERMAN STANDARDIZED right rotation
Shaft	C	CF001 - Milled shank ø10 - thk.5 ("BH" Standard German)
Body	IN	inlet - 3/8" GAS
	OUT	outlet - 3/8" GAS
Cover	A	standard

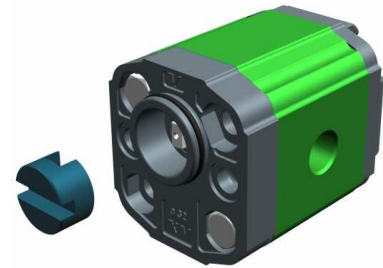

XP161

### Technical data table

TYPE	Displacement cm3/rev	Max. Pressure		CODE	
		P1 bar	P3 bar	Left rotation	Right rotation
XV-1P/0.9	0,91	240	280	X 1 P 16 31 C B B A	X 1 P 16 32 C B B A
XV-1P/1.2	1,17	250	290	X 1 P 17 31 C B B A	X 1 P 17 32 C B B A
XV-1P/1.7	1,56	250	290	X 1 P 18 31 C B B A	X 1 P 18 32 C B B A
XV-1P/2.2	2,08	250	290	X 1 P 20 31 C B B A	X 1 P 20 32 C B B A
XV-1P/2.6	2,60	250	300	X 1 P 21 31 C B B A	X 1 P 21 32 C B B A
XV-1P/3.2	3,12	250	300	X 1 P 23 31 C B B A	X 1 P 23 32 C B B A
XV-1P/3.8	3,64	250	300	X 1 P 25 31 C B B A	X 1 P 25 32 C B B A
XV-1P/4.3	4,16	250	300	X 1 P 27 31 C B B A	X 1 P 27 32 C B B A
XV-1P/4.9	4,94	250	300	X 1 P 29 31 C B B A	X 1 P 29 32 C B B A
XV-1P/5.9	5,85	250	300	X 1 P 31 31 C B B A	X 1 P 31 32 C B B A
XV-1P/6.5	6,50	250	300	X 1 P 32 31 C B B A	X 1 P 32 32 C B B A
XV-1P/7.8	7,54	220	260	X 1 P 34 31 C B B A	X 1 P 34 32 C B B A
XV-1P/9.8	9,88	190	230	X 1 P 36 31 C B B A	X 1 P 36 32 C B B A

P1) Max. working pressure - P3) Max. peak pressure

For heavy-duty applications, it is recommended to check the admissible torque of the shaft

### Dimensions table

TYPE	Weight kg	A	B	C	D	D
		mm	mm	mm	IN	OUT
XV-1P/0.9	0,950	77,1	36,3	65,1	3/8" BSPP	3/8" BSPP
XV-1P/1.2	0,970	78,0	36,8	66,0	3/8" BSPP	3/8" BSPP
XV-1P/1.7	1,010	79,5	37,5	67,5	3/8" BSPP	3/8" BSPP
XV-1P/2.2	1,030	81,5	38,5	69,5	3/8" BSPP	3/8" BSPP
XV-1P/2.6	1,060	83,5	39,5	71,5	3/8" BSPP	3/8" BSPP
XV-1P/3.2	1,090	85,5	40,5	73,5	3/8" BSPP	3/8" BSPP
XV-1P/3.8	1,120	87,5	41,5	75,5	3/8" BSPP	3/8" BSPP
XV-1P/4.3	1,170	89,5	42,5	77,5	3/8" BSPP	3/8" BSPP
XV-1P/4.9	1,200	92,5	44,0	80,5	3/8" BSPP	3/8" BSPP
XV-1P/5.9	1,260	96,0	45,8	84,0	3/8" BSPP	3/8" BSPP
XV-1P/6.5	1,300	97,5	47,0	85,5	3/8" BSPP	3/8" BSPP
XV-1P/7.8	1,360	102,5	49,0	90,5	3/8" BSPP	3/8" BSPP
XV-1P/9.8	1,500	111,5	53,5	99,5	3/8" BSPP	3/8" BSPP

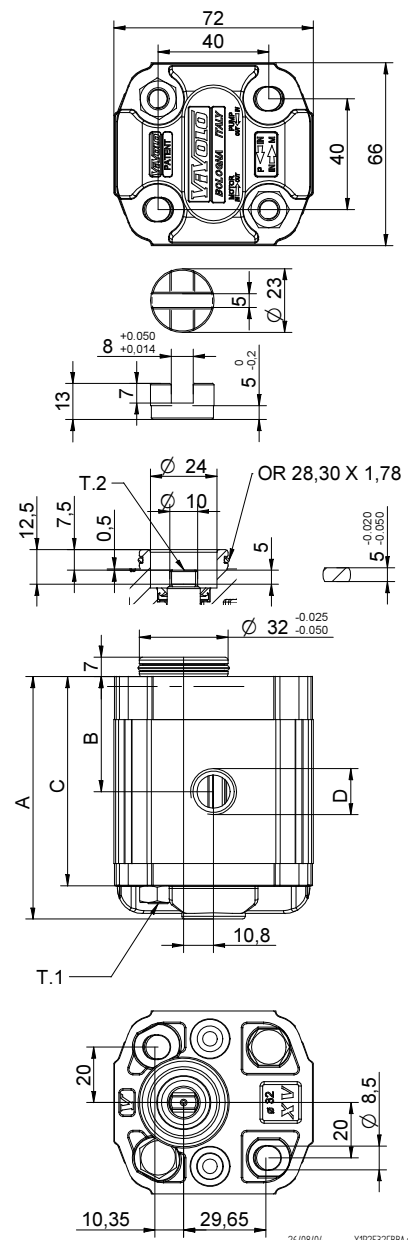

T.1 = 24.5÷29.4 [Nm] - screw tightening torque M8

T.2 = 13.8 [Nm] - admissible shaft torque (N.B. When choosing a shaft, always check the admissible torque).

# Table of variations

**XV-1P**

## Standard German ø32 "BH" FLANGE

Standard German ø32 "BH" FLANGE				Shaft				Cover			
Left rotation		Right rotation		Left rotation		Right rotation		Left rotation		Right rotation	
	<b>31</b>		<b>32</b>	CF001 - Milled shank T.2 = 13.8 [Nm] 	<b>C</b>	SCF01 - Splined T.2 = 42.8 [Nm] m=0,75 Z=15 	<b>Q</b>				<b>A</b>
	<b>33</b>		<b>34</b>	SCF03 - Splined T.2 = 42.8 [Nm] m=0,75 Z=15 	<b>R</b>						<b>B</b>
	<b>35</b>		<b>36</b>								<b>C</b>
	<b>37</b>		<b>38</b>								<b>D</b>

Displacement	
TYPE	CODE
XV-1P/0.9	<b>16</b>
XV-1P/1.2	<b>17</b>
XV-1P/1.7	<b>18</b>
XV-1P/2.2	<b>20</b>
XV-1P/2.6	<b>21</b>
XV-1P/3.2	<b>23</b>
XV-1P/3.8	<b>25</b>
XV-1P/4.3	<b>27</b>
XV-1P/4.9	<b>29</b>
XV-1P/5.9	<b>31</b>
XV-1P/6.5	<b>32</b>
XV-1P/7.8	<b>34</b>
XV-1P/9.8	<b>36</b>

Standard bodies							
Displacement cm3/rev	Standard threads						
	0.9	I - I	B - B	J - J	B - Z	Z - Z	G - F
1.2	I - I	B - B	J - J	B - Z	Z - Z	G - F	
1.7	I - I	B - B	J - J	B - Z	Z - Z	G - F	
2.2	I - I	B - B	J - J	B - Z	Z - Z	G - F	
2.6	I - I	B - B	J - J	B - Z	Z - Z	G - F	
3.2	I - I	B - B	J - J	B - Z	Z - Z	G - F	
3.8	I - I	B - B	J - J	B - Z	Z - Z	G - F	
4.3	I - I	B - B	J - J	B - Z	Z - Z	G - F	
4.9	I - I	B - B	J - J	B - Z	Z - Z	G - F	
5.9	I - I	B - B	J - J	B - Z	Z - Z	G - F	
6.5	I - I	B - B	J - J	B - Z	Z - Z	G - F	
7.8	I - I	B - B	J - J	B - Z	Z - Z	G - F	
9.8	I - I	B - B	J - J	B - Z	Z - Z	G - F	

Table showing standard flange and thread combinations available in stock

		<b>N</b>
Internal drainage		
		<b>O</b>
External drainage		

Body (threads/flanges)							
	<b>A</b>		<b>B</b>		<b>C</b>		<b>D</b>
	<b>E</b>		<b>F</b>		<b>G</b>		
	<b>H</b>		<b>I</b>		<b>J</b>	<b>Closed Body</b>	<b>Z</b>

# unidirectional pump - series XV

**XV-1P**

"SAE AA" TYPE PUMP  
 ø50.8 FLANGE - PARALLEL SHAFT



**X 1 P 25 62 B B B A**

Series	X	series XV
Group	1	group 1
Category	P	unidirectional pump
Displacement	25	3.8
Flange	62	ø50.8 SAE AA right rotation
Shaft	B	CI002 - Parallel ø12.7 - key thk. 3.2 (SAE AA)
Body	IN	inlet - 3/8" GAS
	OUT	outlet - 3/8" GAS
Cover	A	standard



XP168

Technical data table

TYPE	Displacement cm3/rev	Max. Pressure		CODE	
		P1 bar	P3 bar	Left rotation	Right rotation
XV-1P/0.9	0,91	240	280	X 1 P 16 61 B B B A	X 1 P 16 62 B B B A
XV-1P/1.2	1,17	250	290	X 1 P 17 61 B B B A	X 1 P 17 62 B B B A
XV-1P/1.7	1,56	250	290	X 1 P 18 61 B B B A	X 1 P 18 62 B B B A
XV-1P/2.2	2,08	250	290	X 1 P 20 61 B B B A	X 1 P 20 62 B B B A
XV-1P/2.6	2,60	250	300	X 1 P 21 61 B B B A	X 1 P 21 62 B B B A
XV-1P/3.2	3,12	250	300	X 1 P 23 61 B B B A	X 1 P 23 62 B B B A
XV-1P/3.8	3,64	250	300	X 1 P 25 61 B B B A	X 1 P 25 62 B B B A
XV-1P/4.3	4,16	250	300	X 1 P 27 61 B B B A	X 1 P 27 62 B B B A
XV-1P/4.9	4,94	250	300	X 1 P 29 61 B B B A	X 1 P 29 62 B B B A
XV-1P/5.9	5,85	250	300	X 1 P 31 61 B B B A	X 1 P 31 62 B B B A
XV-1P/6.5	6,50	250	300	X 1 P 32 61 B B B A	X 1 P 32 62 B B B A
XV-1P/7.8	7,54	220	260	X 1 P 34 61 B B B A	X 1 P 34 62 B B B A
XV-1P/9.8	9,88	190	230	X 1 P 36 61 B B B A	X 1 P 36 62 B B B A

P1) Max. working pressure - P3) Max. peak pressure

For heavy-duty applications, it is recommended to check the admissible torque of the shaft

Dimensions table

TYPE	Weight kg	A	B	C	D	D
		mm	mm	mm	IN	OUT
XV-1P/0.9	1,000	82,6	41,8	70,6	3/8" BSPP	3/8" BSPP
XV-1P/1.2	1,020	83,5	42,3	71,5	3/8" BSPP	3/8" BSPP
XV-1P/1.7	1,060	85,0	43,0	73,0	3/8" BSPP	3/8" BSPP
XV-1P/2.2	1,080	87,0	44,0	75,0	3/8" BSPP	3/8" BSPP
XV-1P/2.6	1,110	89,0	45,0	77,0	3/8" BSPP	3/8" BSPP
XV-1P/3.2	1,140	91,0	46,0	79,0	3/8" BSPP	3/8" BSPP
XV-1P/3.8	1,170	93,0	47,0	81,0	3/8" BSPP	3/8" BSPP
XV-1P/4.3	1,220	95,0	48,0	83,0	3/8" BSPP	3/8" BSPP
XV-1P/4.9	1,250	98,0	49,5	86,0	3/8" BSPP	3/8" BSPP
XV-1P/5.9	1,310	101,5	51,3	89,5	3/8" BSPP	3/8" BSPP
XV-1P/6.5	1,350	105,0	52,5	93,0	3/8" BSPP	3/8" BSPP
XV-1P/7.8	1,410	108,0	54,5	96,0	3/8" BSPP	3/8" BSPP
XV-1P/9.8	1,550	117,0	59,0	105,0	3/8" BSPP	3/8" BSPP

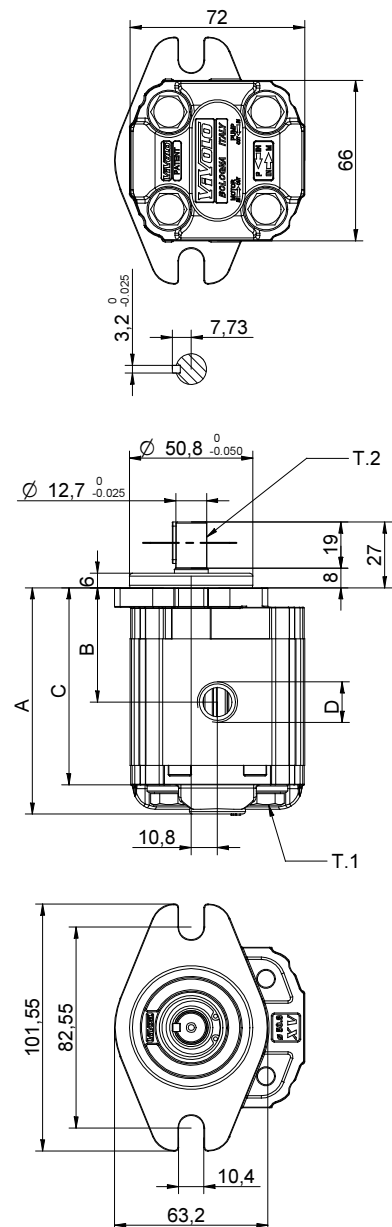

T.1 = 24.5÷29.4 [Nm] - screw tightening torque M8

T.2 = 32.8 [Nm] - admissible shaft torque (N.B. When choosing a shaft, always check the admissible torque).



# Table of variations

**XV-1P**

## ø50.8 FLANGE "SAE AA"

ø50.8 FLANGE "SAE AA"		Shaft		Cover			
Left rotation	Right rotation			Left rotation	Right rotation		
		<b>CI001 - Parallel</b> T.2 = 25.8 [Nm] 	<b>A</b>	<b>CI002 - Parallel</b> T.2 = 32.8 [Nm] SAE 	<b>B</b>	 	<b>A</b>
<b>61</b>	<b>62</b>	<b>CF003 - Milled shank</b> T.2 = 25.9 [Nm] SAE 	<b>E</b>	<b>CO002 - Tapered</b> T.2 = 119.8 [Nm] 	<b>G</b>	 	<b>B</b>
		<b>CO004 - Tapered</b> T.2 = 90.4 [Nm] SAE 	<b>I</b>	<b>SCF05 - Splined</b> T.2 = 32.2 [Nm] SAE J 498 9T 20/40 DP 	<b>K</b>	 	<b>C</b>
		<b>CO002+HK - Tapered</b> T.2 = 119.8 [Nm] HK 14-12 	<b>O</b>	<b>CI001+HK - Parallel</b> T.2 = 25.8 [Nm] HK 14-12 	<b>P</b>	 	<b>D</b>
						 	<b>N</b>
						 	<b>O</b>

Displacement	
TYPE	CODE
XV-1P/0.9	<b>16</b>
XV-1P/1.2	<b>17</b>
XV-1P/1.7	<b>18</b>
XV-1P/2.2	<b>20</b>
XV-1P/2.6	<b>21</b>
XV-1P/3.2	<b>23</b>
XV-1P/3.8	<b>25</b>
XV-1P/4.3	<b>27</b>
XV-1P/4.9	<b>29</b>
XV-1P/5.9	<b>31</b>
XV-1P/6.5	<b>32</b>
XV-1P/7.8	<b>34</b>
XV-1P/9.8	<b>36</b>

Standard bodies							
Displacement cm3/rev	Standard threads						
	0.9	I - I	B - B	J - J	B - Z	Z - Z	G - F
1.2	I - I	B - B	J - J	B - Z	Z - Z	G - F	
1.7	I - I	B - B	J - J	B - Z	Z - Z	G - F	
2.2	I - I	B - B	J - J	B - Z	Z - Z	G - F	
2.6	I - I	B - B	J - J	B - Z	Z - Z	G - F	
3.2	I - I	B - B	J - J	B - Z	Z - Z	G - F	
3.8	I - I	B - B	J - J	B - Z	Z - Z	G - F	
4.3	I - I	B - B	J - J	B - Z	Z - Z	G - F	
4.9	I - I	B - B	J - J	B - Z	Z - Z	G - F	
5.9	I - I	B - B	J - J	B - Z	Z - Z	G - F	
6.5	I - I	B - B	J - J	B - Z	Z - Z	G - F	
7.8	I - I	B - B	J - J	B - Z	Z - Z	G - F	
9.8	I - I	B - B	J - J	B - Z	Z - Z	G - F	

Table showing standard flange and thread combinations available in stock

Body (threads/flanges)							
	<b>A</b>		<b>B</b>		<b>C</b>		<b>D</b>
	<b>E</b>		<b>F</b>		<b>G</b>		
	<b>H</b>		<b>I</b>		<b>J</b>	<b>Closed Body</b>	<b>Z</b>