

STEERING COLUMNS TYPE KK...



The M+S Hydraulic KK Steering Columns transfer the torque from the steering wheel of the vehicle to the HKU, HKUS or other steering units of the same class. The KK steering columns consist of a pipe in which the control shaft is centred.

Permissible loads of the steering column are as follows:

Max. torque applied to the steering wheel 24 daNm [2124 lb-in]
 Max. bending moment 20 daNm [1770 lb-in]
 Max. axial load 100 daN [225 lbs]

The steering column must be additionally supported when the length L exceeds 150 mm [5.91 in].

DIMENSIONS AND MOUNTING DATA

Type KK

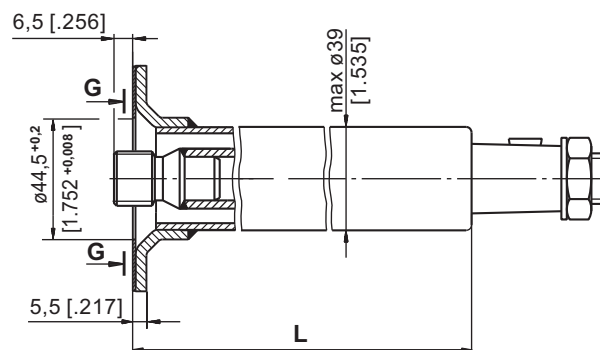
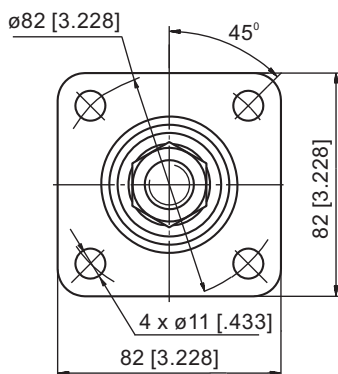

Type KKF

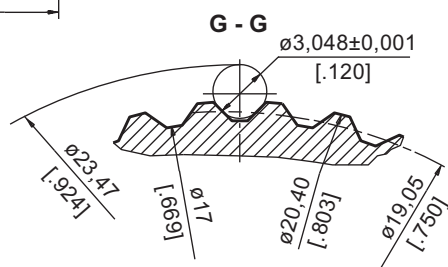
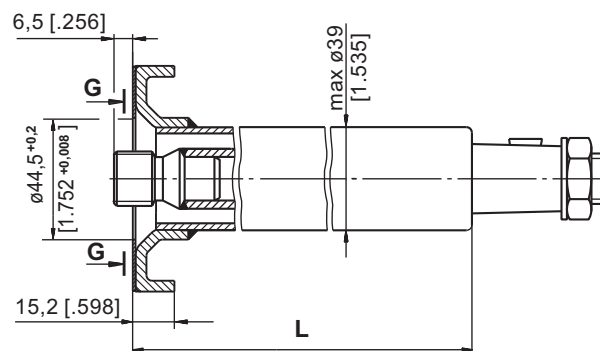
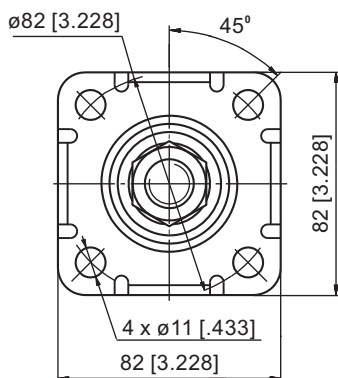

SPECIFICATION DATA

Involute Spline Data		
Modul	m	1.5875
Number of Teeth	z	12
Pressure Angle	α	30°
Diametral Pitch	DP	16/32

Parameters	Type	Type				
		KK 75	KK 150	KK 390	KK 441	KK 750
L	mm [in]	78 [3.07]	168,2 [6.62]	393 [15.47]	441 [17.36]	777,8 [30.62]
Weight	kg [lb]	0,75 [1.65]	1,1 [2.43]	1,9 [4.19]	5,05 [11.13]	3,3 [7.28]

Note: The length L depends on the transport vehicle construction. For more information regarding other lengths and shaft versions, please refer to M+S Hydraulic.

SOUND SIGNAL CONNECTION

E Option

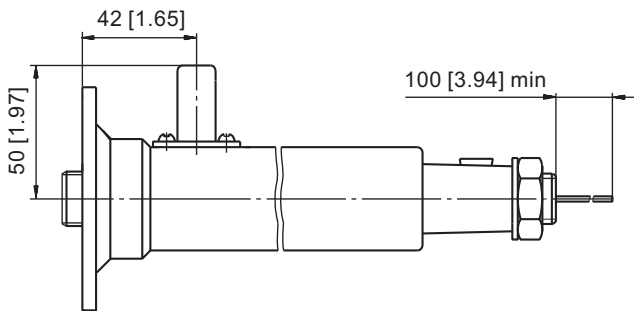

EE Option

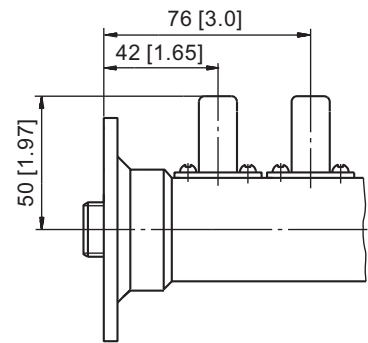

Shaft End Part

Order No: 46415 001 00

Involute Spline Data		
Modul	m	1.5875
Number of Teeth	z	12
Pressure Angle	α	30°
Diametral Pitch	DP	16/32

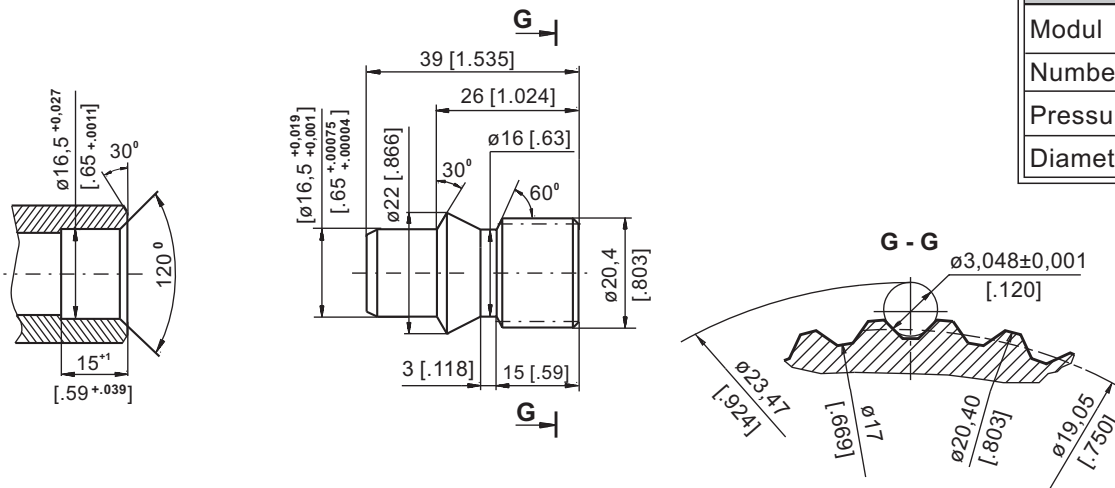

SHAFT VERSIONS

TYPE I

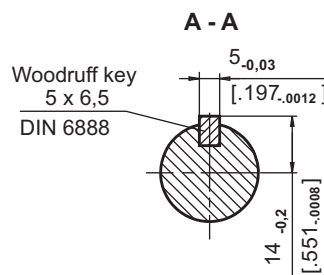
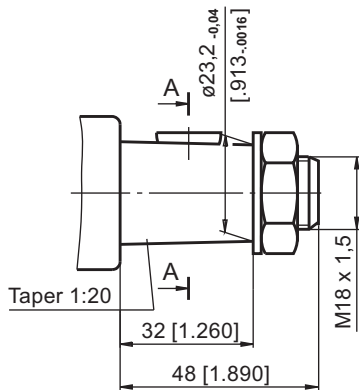

TYPE II

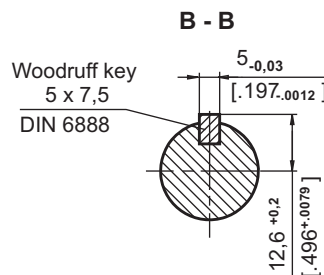
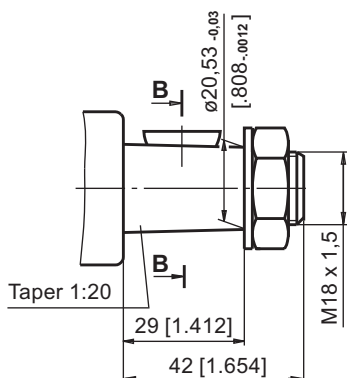

TYPE III

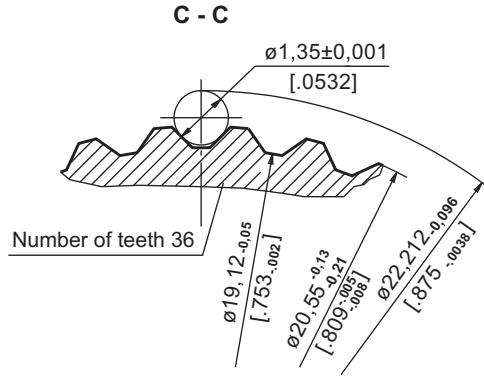
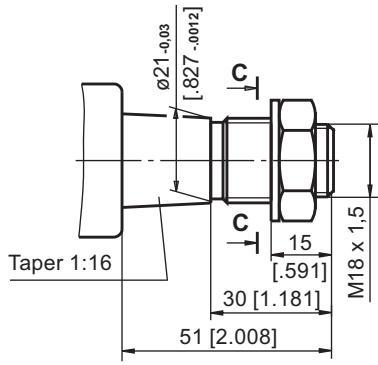

TYPE IV

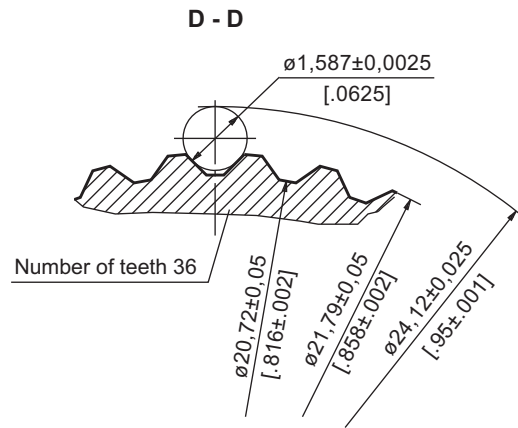
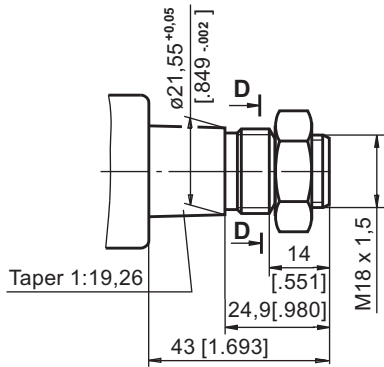

TYPE V

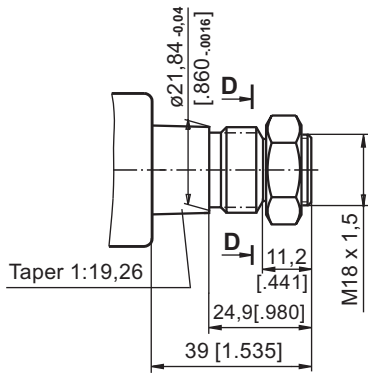

TYPE VI

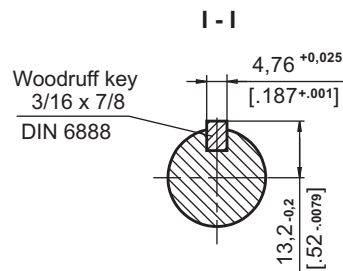
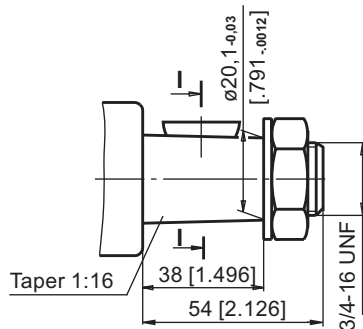

TYPE VII

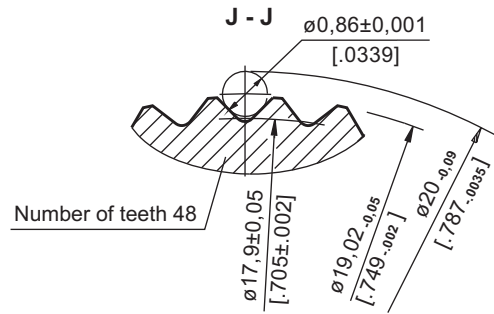
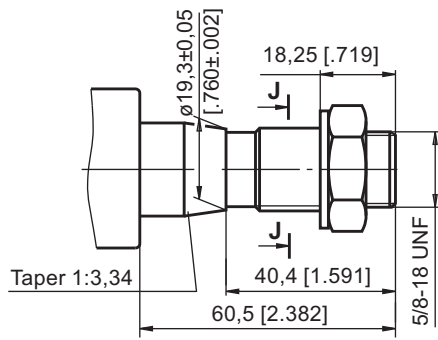

TYPE VIII

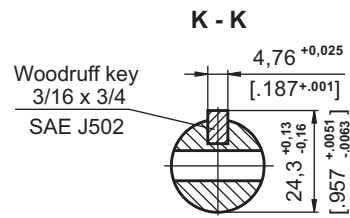
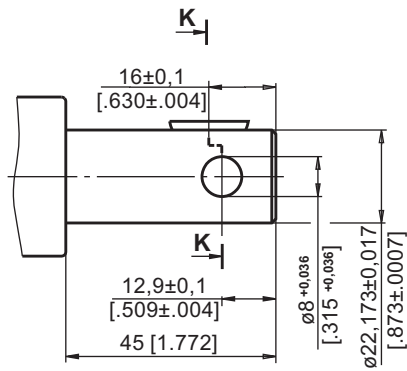

TYPE IX

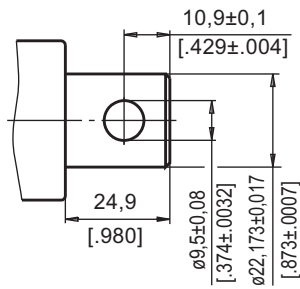

TYPE XIII

