

## Installation and maintenance

1. Installation: when install the manhole cover, the upper and lower platen should be perpendicular to the length direction of the The truck beam. During installation and handling, pay attention to no damage the installation joint surface of the manhole cover, so as not to affect the sealing performance. The seal gasket between manhole cover and oil tank is provided by our company. Take care not to damage it.
2. Use: the manhole cover has been adjusted well before delivery. It can be used after installation. During using, do not adjust the vent valve and emergency vent valve device (such as spring, etc.) at will. If there is any abnormal situation. Please contact us.
3. Operation: open in the following order:
  - (1.1) Insert the key into the keyhole of the manhole cover.
  - (1.2) Turn the key counterclockwise about 30 degrees,
  - (1.3) It can be forced upward to move the upper platen.
  - (1.4) Push the lock hook in the square hole of the lower platen and lift up one end of the lower platen to open the small manhole cover.
- (2) Close the manhole cover
  - (2.1) Move one end of the lower platen to rotate around the fixed shaft to close the manhole cover.
  - (2.2) Move one end of the upper platen to rotate and pressurize around the fixed shaft until it is locked.
4. Maintenance: inspect and clean the sealing surface, spring and other parts irregularly to keep a good working condition

## Contact

### WENZHOU LIDUN MACHINERY EQUIPMENT CO., LTD

Add.: No.10 Weiyi Road, Lantian Industrial Zone, Wenzhou, China.

Tel: 0577-86855786

Phone: +86 15058902017

Postal code: 325000

E-mail: [tankerparts\\_lin@hotmail.com](mailto:tankerparts_lin@hotmail.com)



**SINCE 1997**

## Manhole Cover

### Installation and Operation Instruction

Model: LDAL-507



## Product Introduction

Manhole cover is installed on the top of oil tanker. It is the internal inlet of loading, checking vapor recovery and tanker maintenance. It can protect the tanker from emergency.

Normally, the breathing valve is closed. However, when load unload oil external temperature changes, and the pressure of tanker will change such as air pressure and vacuum pressure. The breathing valve can automatically open at a certain air pressure and vacuum pressure to make the tank pressure in normal condition. If there is emergency like roll over situation, it will automatically close and it also can avoid the tanker explosion when in fires. As the emergency exhausting valve will automatically open when tank truck interior pressure increases to a certain range.

## Product Feature

- ◆ Each manhole cover emergency exhausting valve includes a breathing valve.
  - ◆ The breathing valve is installed as required to make the tanker ventilated.
- Different pressure settings suit different operation requirements.
- ◆ Emergency exhausting valve and breathing valve has automatic sealing to prevent danger and needless oil spillage.
  - ◆ Double open allows safe release of remaining gas before fully opening the cover board.
  - ◆ Two reserved blind holes on the main cover can be installed with vapor recovery valve and optic sensor.
  - ◆ According to EN13317:2002 standard.

## Specifications

Size: DN580  
 Emergency exhausting valve: 10"  
 Working pressure: 0.254MPa  
 Emergency open pressure: 21KPa-32KPa  
 Max flow rate: 7000m<sup>3</sup>/h  
 Connection mode: Flanged  
 Temperature range: -20+70°C

## Dimensions:

Spec.	D	D0	n- φ D1
Model			
LDAL-502	580	530	24- φ 11

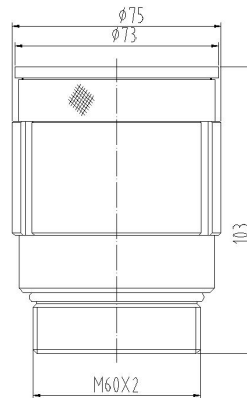

The vent valve drawing

drawing:

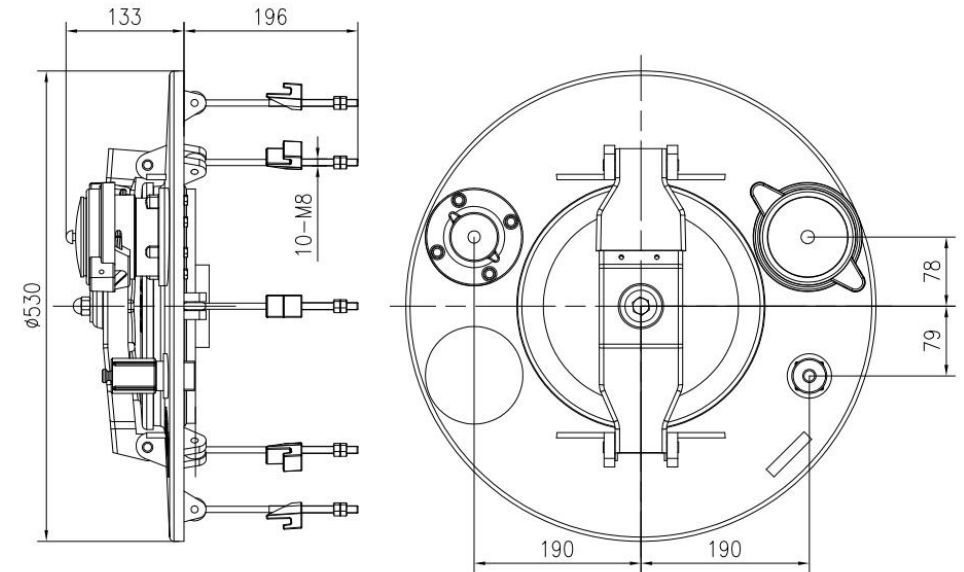

**WENZHOU LIDUN MACHINERY EQUIPMENT CO., LTD**