

PISTON PUMPS RANGE

"HDS" "MDS"
"HDT"

VERSIONS CODING

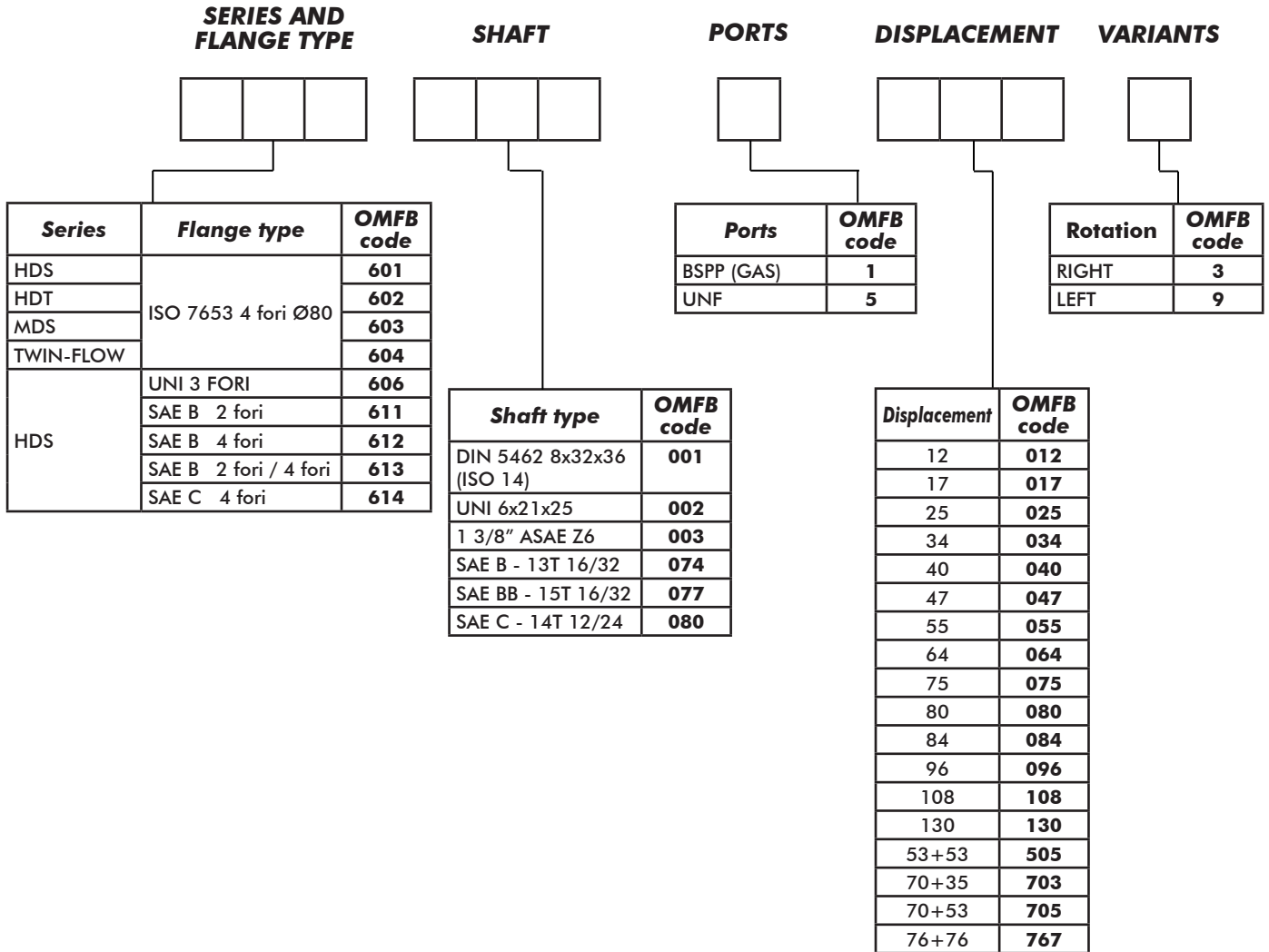

99740060010

POMPE A PISTONI AD ASSE INCLINATO BENT AXIS PISTON PUMPS

CODICE FAMIGLIA
FAMILY CODE

602001

"HDT"

Flangia/Flange
Albero/Shaft
Cilin./Displ.

ISO
ISO14 8x32x36
75-84-96-108



99740060010

Fluido idraulico Fluid	Minerale o sintetico compatibile con guarnizioni: Mineral or synthetic compatible with the following seals: HNBR				
Temp. consentita Allowed temperature	-40 +140 °C				
Viscosità cinematica consigliata Kinematic viscosity suggested	T media ambiente (°C) Average ambient temp. (°C)	< -40	-40 ÷ 10	10 ÷ 35	> 35
	VG (cSt = mm ² /s)	16	22	32	46
Viscosità cinematica ottimale di esercizio Optimale kinematic viscosity		VG = 10 cSt ÷ 100 cSt			
Viscosità cinematica max consentita all'avviamento Max kinematic viscosity suggested at the start-up		VG = 750 cSt			
Indice di viscosità consigliato Viscosity index suggested		VI > 100			
Grado di filtrazione Oil filtering		> 200 bar: 10 µm < 200 bar: 25 µm			
Pres. di aspirazione Inlet pressure		0,85 ÷ 2 bar assoluti/absolut			
Senso di rotazione Pump rotation		Unidirezionale (Dx o Sx) Unidirectional (Right or Left)			
Verificare che la pompa sia posizionata almeno 100 mm sotto il livello minimo del serbatoio olio. Prima di avviare la pompa effettuare spurgo aria. Verify that pump is, at least, 100 mm under the minimum level of the tank. Before starting the pump bleed the air.					

Dimensions in mm

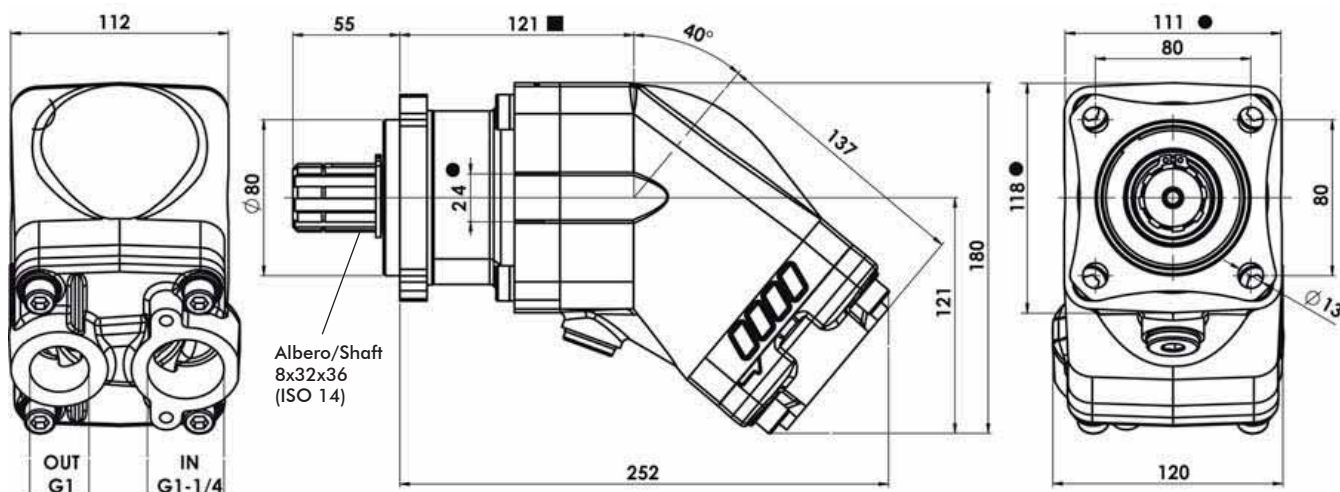

● Larghezza minima corpo a quota indicata ■
Minimum bodywidth at indicated measurement

Tipo pompa Pump type	Rotazione Rotation		IN	OUT
	Destra Right	Sinistra Left		
HDT-75	60200110753	60200110759	ISO 228	ISO 228
HDT-84	60200110843	60200110849	G 1 1/4"	G 1"
HDT-96	60200110963	60200110969		
HDT-108	60200111083	60200111089		
HDT-75	60200150753	60200150759	ISO 725	ISO 725
HDT-84	60200150843	60200150849	1 5/8-12 UN-2B SAE 20	1 5/16-12 UN-2B SAE 16
HDT-96	60200150963	60200150969		
HDT-108	60200151083	60200151089		

pag. 43

O.M.F.B. S.p.A. Hydraulic Components

We reserve the right to make any changes without notice.

Edition 2016.06 No reproduction, however partial, is permitted.

Via Cave, 7/9 25050 Provaglio d'Iseo (Brescia) Italy Tel.: +39.030.9830611
Fax: +39.030.9839207-208 Internet: www.omfb.it e-mail: contatti@omfb.it

COMPANY WITH
QUALITY SYSTEM
CERTIFIED BY DNV GL
= IATF 16949 =

OMFB

HYDRAULIC COMPONENTS

07/03/2017

99760201301 Rev. AA

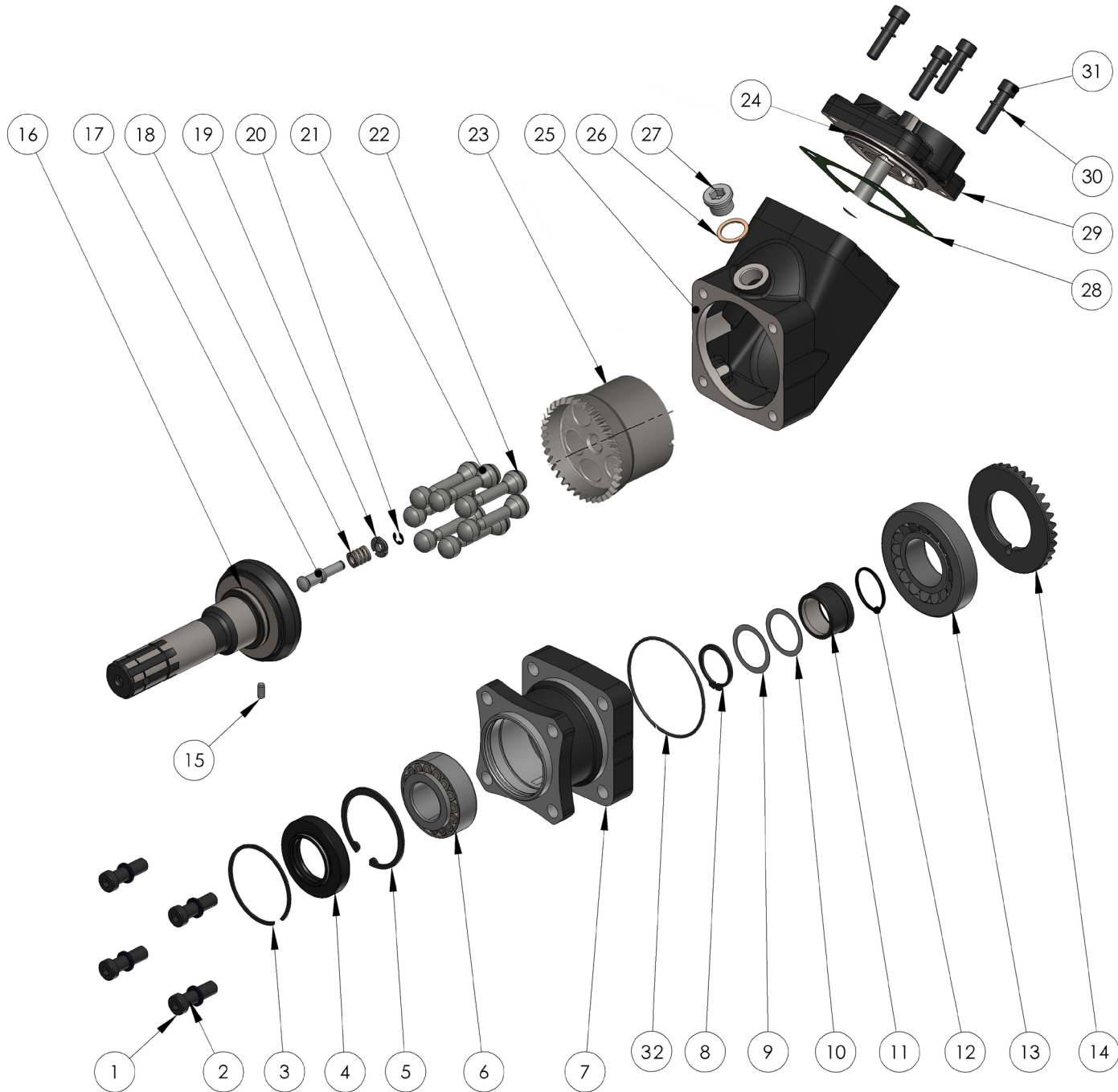



O.M.F.B. S.p.A. Hydraulic Components
 We reserve the right to make any changes without notice.
 Edition 2016.06 No reproduction, however partial, is permitted.
 Via Cove, 719 25050 Poggiole d'Isco (Brescia) Italy. Tel.: +39 030 9830611
 Fax: +39 030 9839207 208 Internet: www.omfb.it e-mail: conatti@omfb.it

pag. 45

COMPANY WITH
 QUALITY SYSTEM
 CERTIFIED BY DNV GL
 = IATF 16949 =

N°	HDT 75		HDT 84		HDT 96		HDT 108		Codice / Code	Descrizione / Description		Q.
	GAS	SAE	GAS	SAE	GAS	SAE	GAS	SAE				
1	•	•	•	•	•	•	•	•	50200500564	Vite TCE M 12x40	Socket head capscrew	4
2	•	•	•	•	•	•	•	•	50102000129	Rosetta elastica	Washer	4
3	•	•	•	•	•	•	•	•	50100002729	Anello elastico	Circlip	1
4	•	•	•	•	•	•	•	•	50600024272	Paraolio	Oil seal	1
5	•	•	•	•	•	•	•	•	50100100677	Anello elastico	Circlip	1
6	•	•	•	•	•	•	•	•	51000200220	Cuscinetto a rulli conici	Tapered roller bearing	1
7	•	•	•	•	•	•	•	•	51700201707	Corpo anteriore	Front housing	1
8	•	•	•	•	•	•	•	•	50100001355	Anello seeger	Retaining ring	1
9	•	•	•	•	•	•	•	•	52900700226	Rondella	Washer	1
10	•	•	•	•	•	•	•	•	52900701127	Rondella	Washer	1
11	•	•	•	•	•	•	•	•	51100200200	Bussola	Bushing	1
12	•	•	•	•	•	•	•	•	50600013137	Guarnizione OR 3137 HNBR	O-ring 3137 HNBR	1
13	•	•	•	•	•	•	•	•	51000200294	Cuscinetto a rulli conici	Tapered roller bearing	1
14	•	•	•	•	•	•	•	•	52501100282	Corona dentata	Crown	1
15	•	•	•	•	•	•	•	•	50100306142	Spina UNI 6364-A	Pin UNI 6364-A	1
16	•	•	•	•	•	•	•	•	52200500375	Albero	Shaft	1
17	•	•	•	•	•	•	•	•	54200100162	Perno sferico con guida albero	Shaft guide pin	1
18	•	•	•	•	•	•	•	•	51200500812	Molla di carico corpo cilindri	Spring	1
19	•	•	•	•	•	•	•	•	54200100171	Anello guida molla	Spring guide ring	1
20	•	•	•	•	•	•	•	•	50101500028	Anello seeger	Retaining ring	1
21	•	•	•	•	•	•	•	•	53200500294	Pistone sferico	Piston	7
	•	•	•	•	•	•	•	53200500034				
	•	•	•	•	•	•	•	53200500276				
	•	•	•	•	•	•	•	53200500070				
22	•	•	•	•	•	•	•	•	50102300019	Fasce elastiche	Spring rings	21
	•	•	•	•	•	•	•	50102300037				
	•	•	•	•	•	•	•	50102300091				
	•	•	•	•	•	•	•	50102300055				
23	•	•	•	•	•	•	•	•	50002916075	Gruppo corpo cilindri sede pistoni	Piston barrel assembly	1
	•	•	•	•	•	•	•	50002916085				
	•	•	•	•	•	•	•	50002916096				
	•	•	•	•	•	•	•	50002916109				
24	•	•	•	•	•	•	•	50600013300	Guarnizione OR 3300 HNBR	O-Ring 3300 HNBR	1	
25	•	•	•	•	•	•	•	51700201458	Corpo intermedio	Int. housing	1	
26	•	•	•	•	•	•	•	11600910129	Rondella acciaio/gomma 1/2	Steel/rubber washer 1/243	1	
27	•	•	•	•	•	•	•	11500600135	Tappo cieco	Blank plug	1	
28	A	A	A	A	A	A	A	A	50700000381	Guarnizione piatta	Gasket	1
	A	A	A	A	A	A	A	A	50700000489			
29	•	•	•	•	•	•	•	•	50002980751	Gruppo corpo posteriore	Rear cover assembly	1
	•	•	•	•	•	•	•	•	50002980760			
	•	•	•	•	•	•	•	•	50002980859			
	•	•	•	•	•	•	•	•	50002980868			
	•	•	•	•	•	•	•	•	50002980966			
	•	•	•	•	•	•	•	•	50002980975			
	•	•	•	•	•	•	•	•	50002981107			
30	•	•	•	•	•	•	•	•	50002981116	Rosetta SCHNORR	SCHNORR Washer	4
	•	•	•	•	•	•	•	•	50102000101			
31	•	•	•	•	•	•	•	•	50200400574	Vite TCE M10x45	Socket head capscrew	4
32	•	•	•	•	•	•	•	•	50600012387	Guarnizione OR 2387 HNBR	O-ring 2387 HNBR	1

A = alternative

CARATTERISTICHE TECNICHE DI FUNZIONAMENTO / TECHNICAL FEATURES

Tipo pompa Pump type	Cilindrata Displacement cm ³ /rev	Pressione Pressure		Velocità / Speed			Velocità min. Min. speed rpm	Peso Weight kg
		P1 bar	P3 bar	V0 rpm	V1 rpm	V2 rpm		
HDT-75	75,5	350	370	2300	1500	2000	300	14,9
HDT-84	84,2							14,7
HDT-96	95,5							14,7
HDT-108	107							14,5

P1=Pressione massima continua Max. continuous pressure (100%)
P3=Pressione massima di punta Max. peak pressure (6 sec.max)

V0=Massima continua vuoto Max. continuous speed without load
V1=Massima continua Max. continuous speed
V2=Massima intermittente Max. intermittent speed

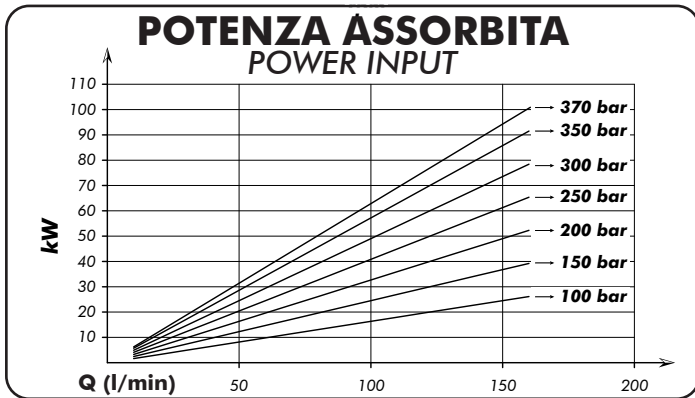
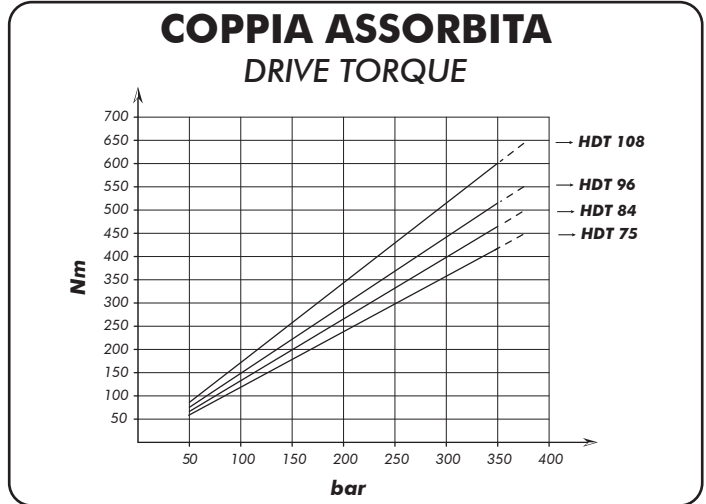
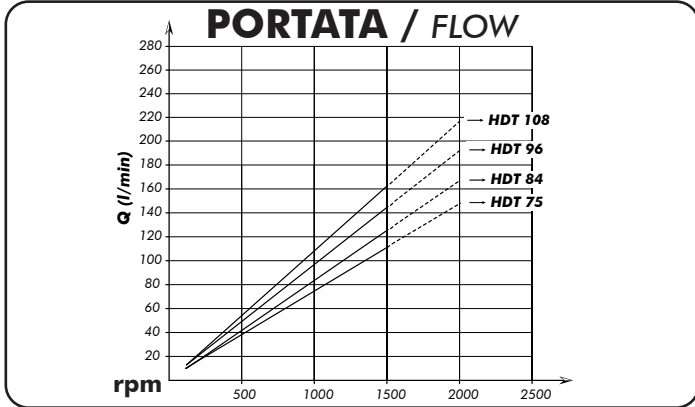

Kit guarnizioni / Seal Kit
10890385008

SCELTA DEL TUBO DI ASPIRAZIONE HOW TO CHOOSE THE SUCTION PIPE SIZE

Q Portata Flow l/min	Ø interno min. tubo Min pipe diam.		Velocità flusso Flow speed (m/s)
	mm	inch	
20	25	1"	0,68
30	32	1" 1/4	0,62
40	32	1" 1/4	0,83
50	38	1" 1/2	0,74
60	38	1" 1/2	0,88
70	40	1" 9/16	0,93
80	45	1" 3/4	0,84
90	45	1" 3/4	0,94
100	50	2"	0,85
110	50	2"	0,93
120	60	2" 3/8	0,71
130	60		0,77
140	60		0,83
150	60	2" 1/2	0,88
160	63		0,86
170	63		0,91
180	63	2" 1/2	0,96

Per garantire corrette condizioni di aspirazione la velocità del flusso non deve superare 1 m/sec.
To ensure the proper suction pipe size the flow speed should not exceed 1mt/sec.

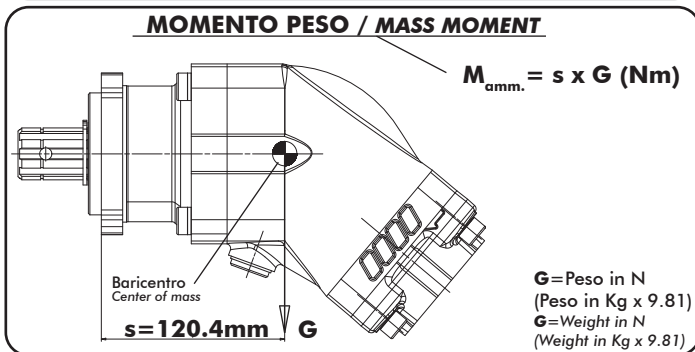
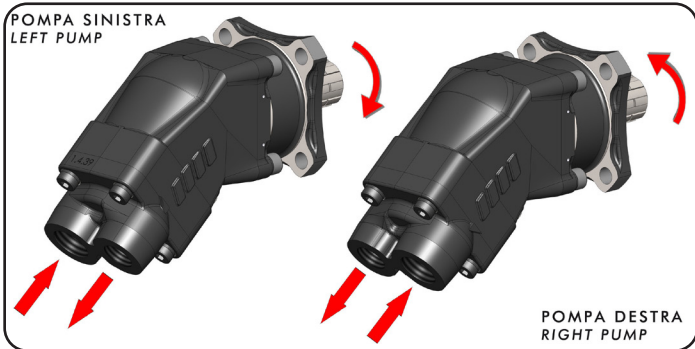

POMPE A PISTONI AD ASSE INCLINATO BENT AXIS PISTON PUMPS

CODICE FAMIGLIA
FAMILY CODE

602003.....F

"HDT"

Flangia/Flange
Albero/Shaft
Cilindrata/Displacement

ISO
ASAE 1"3/8
84-108

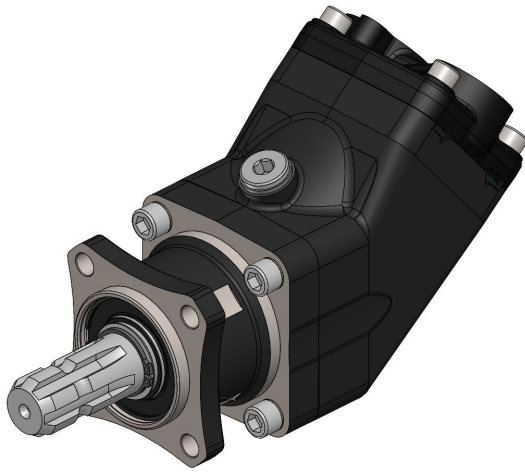

99740060010

Fluido idraulico Fluid	Minerale o sintetico compatibile con guarnizioni: Mineral or synthetic compatible with the following seals: HNBR				
Temp. consentita Allowed temperature	-40 +140 °C				
Viscosità cinematica consigliata Kinematic viscosity suggested	T media ambiente (°C) Average ambient temp. (°C)	< -40	-40 ÷ 10	10 ÷ 35	> 35
	VG (cSt = mm ² /s)	16	22	32	46
Viscosità cinematica ottimale di esercizio Optimale kinematic viscosity		VG= 10 cSt ÷ 100 cSt			
Viscosità cinematica max consentita all'avviamento Max kinematic viscosity suggested at the start-up		VG= 750 cSt			
Indice di viscosità consigliato Viscosity index suggested		VI > 100			
Grado di filtrazione Oil filtering		> 200 bar: 10 µm < 200 bar: 25 µm			
Pres. di aspirazione Inlet pressure		0,85 ÷ 2 bar assoluti/absolut			
Senso di rotazione Pump rotation		Unidirezionale sinistra Unidirectional left			

Verificare che la pompa sia posizionata almeno 100 mm sotto il livello minimo del serbatoio olio. Prima di avviare la pompa effettuare spurgo aria.
Verify that pump is, at least, 100 mm under the minimum level of the tank. Before starting the pump bleed the air.

Dimensions in mm

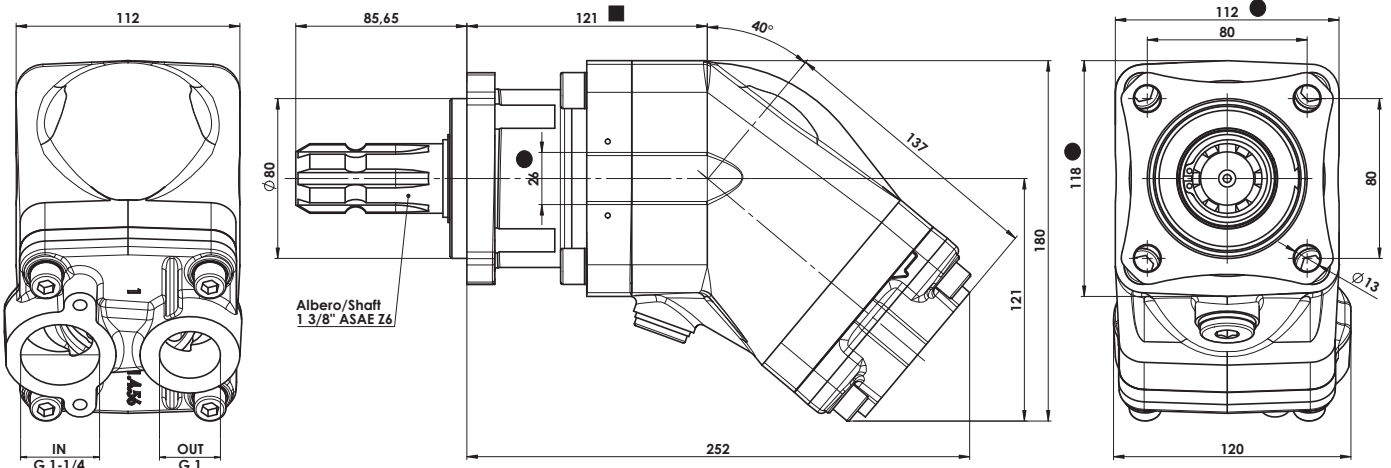

● Larghezza minima corpo a quota indicata ■
Minimum bodywidth at indicated measurement

Tipo pompa Pump type	Rotazione sinistra Left rotation	IN ISO 228	OUT ISO 228
HDT-84	60200310849F	G 1-1/4	G 1
HDT-108	60200311089F		



Nota: la pompa ha senso di rotazione fisso (suffisso F nel codice). Non è possibile invertire il senso di rotazione ruotando il corpo posteriore.

ATTENTION: the pump has fixed sense of rotation (suffix F on part number). It is NOT POSSIBLE to change pump rotation by turning rear-body as in standard version!

pag.47

O.M.F.B. S.p.A. Hydraulic Components

We reserve the right to make any changes without notice.

Edition 2016.06 No reproduction, however partial, is permitted.

Via Cave, 7/9 25050 Provaglio d'Iseo (Brescia) Italy Tel.: +39.030.9830611
Fax: +39.030.9839207-208 Internet:www.omfb.it e-mail:contatti@omfb.it

COMPANY WITH
QUALITY SYSTEM
CERTIFIED BY DNV GL
= IATF 16949 =

OMFB

HYDRAULIC COMPONENTS

31/05/2023

99760200310 Rev. AA

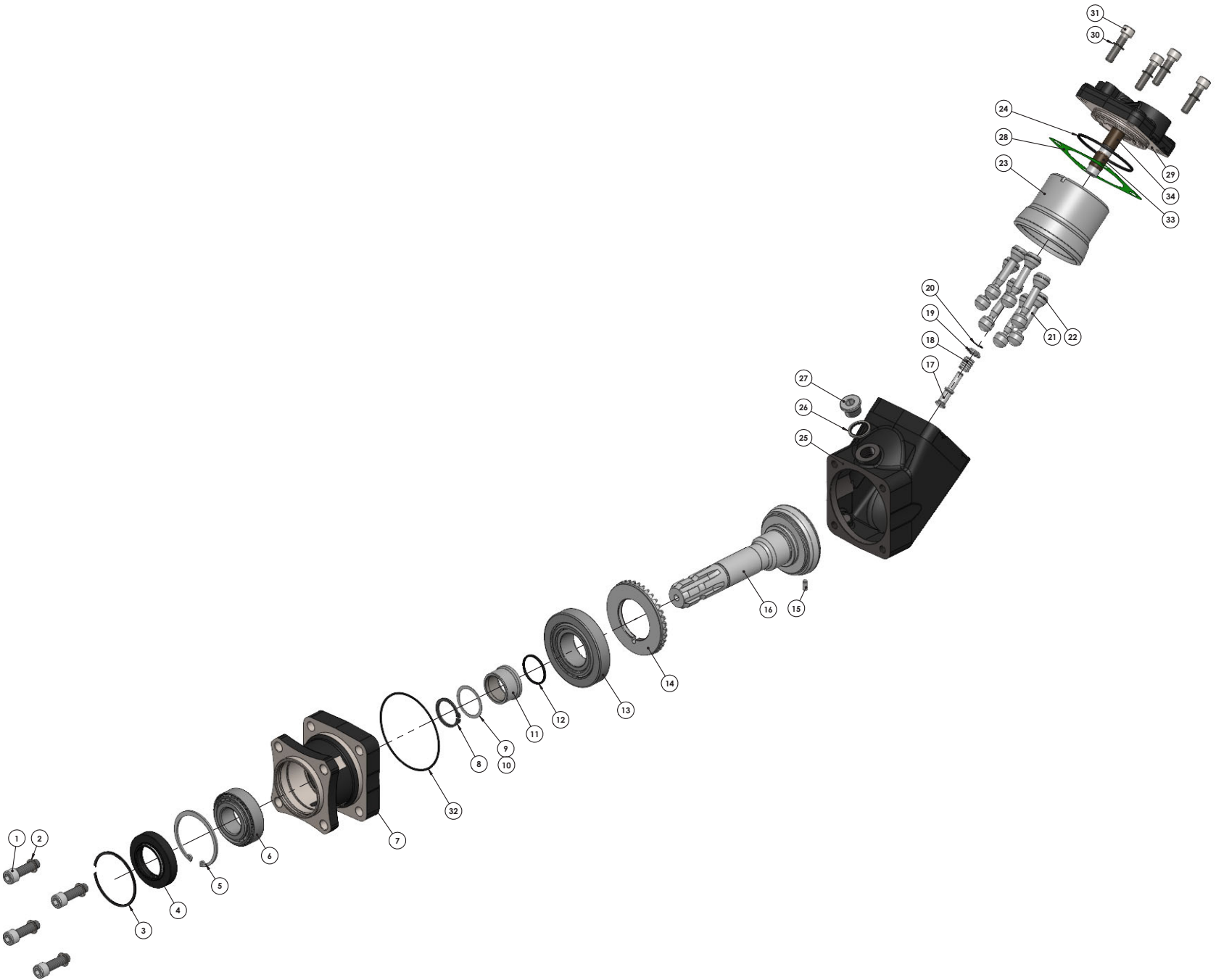

N°	HDT 84	HDT 108	Codice / Code	Descrizione / Description		Q.
1	•	•	50200500564	Vite TCE M 12x40	Socket head capscrew	4
2	•	•	50102000129	Rosetta elastica	Washer	4
3	•	•	50100002729	Anello elastico	Circlip	1
4	•	•	50600024272	Paraolio	Oil seal	1
5	•	•	50100100677	Anello elastico	Circlip	1
6	•	•	51000200220	Cuscinetto a rulli conici	Tapered roller bearing	1
7	•	•	51700201707	Corpo anteriore	Front housing	1
8	•	•	50100001355	Anello seeger	Retaining ring	1
9	•	•	52900700226	Rondella	Washer	1
10	•	•	52900701127	Rondella	Washer	1
11	•	•	51100200200	Bussola	Bushing	1
12	•	•	50600013137	Guarnizione OR 3137 HNBR	O-ring 3137 HNBR	1
13	•	•	51000200294	Cuscinetto a rulli conici	Tapered roller bearing	1
14	•	•	52501100282	Corona dentata	Crown	1
15	•	•	50100306142	Spina UNI 6364-A	Pin UNI 6364-A	1
16	•	•	52200500446	Albero	Shaft	1
17	•	•	54200100162	Perno sferico con guida albero	Shaft guide pin	1
18	•	•	51200500812	Molla di carico corpo cilindri	Spring	1
19	•	•	54200100171	Anello guida molla	Spring guide ring	1
20	•	•	50101500028	Anello seeger	Retaining ring	1
21	•	•	53200500034	Pistone sferico	Piston	7
22	•	•	50102300037	Fasce elastiche	Spring rings	21
23	•	•	51700300734	Gruppo corpo cilindri sede pistoni	Piston barrel assembly	1
24	•	•	50600013300	Guarnizione OR 3300 HNBR	O-Ring 3300 HNBR	1
25	•	•	51700201458	Corpo intermedio	Int. housing	1
26	•	•	11600910129	Rondella acciaio/gomma 1/2	Steel/rubber washer 1/243	1
27	•	•	11500600135	Tappo cieco	Blank plug	1
28	A	A	50700000381	Guarnizione piatta 0,3mm	Gasket	1
	A	A	50700000489	Guarnizione piatta 0,5mm	Gasket	1
29	•	•	50002980877	Gruppo corpo posteriore (sinistro)	Rear cover assembly (left)	1
	•	•	50002981125	Gruppo corpo posteriore (sinistro)	Rear cover assembly (left)	1
30	•	•	50102000101	Rosetta SCHNORR	SCHNORR Washer	4
31	•	•	50200400574	Vite TCE M10x45	Socket head capscrew	4
32	•	•	50600012387	Guarnizione OR 2387 HNBR	O-ring 2387 HNBR	1
33	•	•	53300400328	Boccola DU 16x18x25	Bushing	1
34	•	•	53300400337	Boccola DU 16x18x20	Bushing	1

A = alternative

CARATTERISTICHE TECNICHE DI FUNZIONAMENTO / TECHNICAL FEATURES

Tipo pompa Pump type	Cilindrata Displacement cm ³ /rev	Pressione Pressure		Velocità / Speed			Velocità min. Min. speed rpm	Peso Weight kg
		P1 bar	P3 bar	V0 rpm	V1 rpm	V2 rpm		
HDT-84	84,2	350	370	2300	1500	2000	300	15
HDT-108	107							

P1=Pressione massima continua Max. continuous pressure (100%)
P3=Pressione massima di punta Max. peak pressure (6 sec.max)

V0=Massima continua vuoto Max. continuous speed without load
V1=Massima continua Max. continuous speed
V2=Massima intermittente Max. intermittent speed

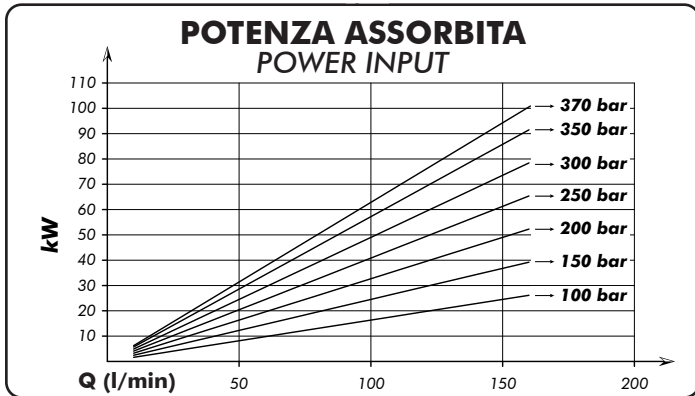
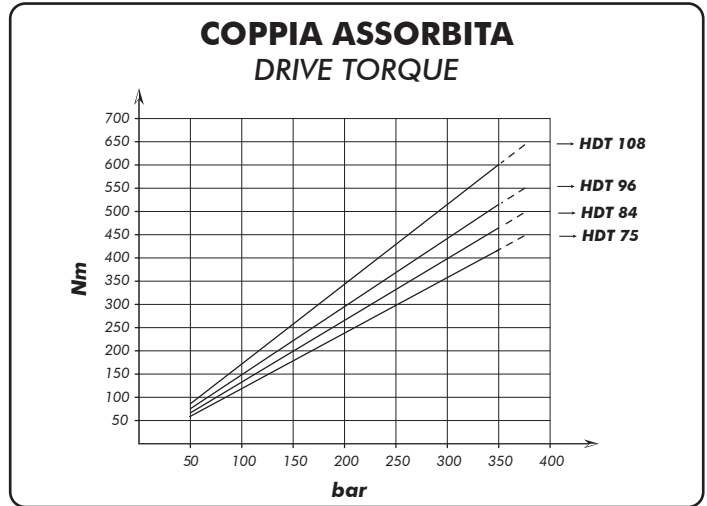
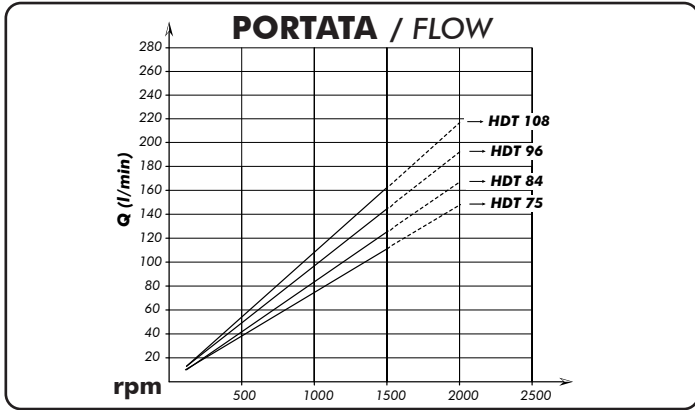

Kit guarnizioni / Seal Kit
10890385008

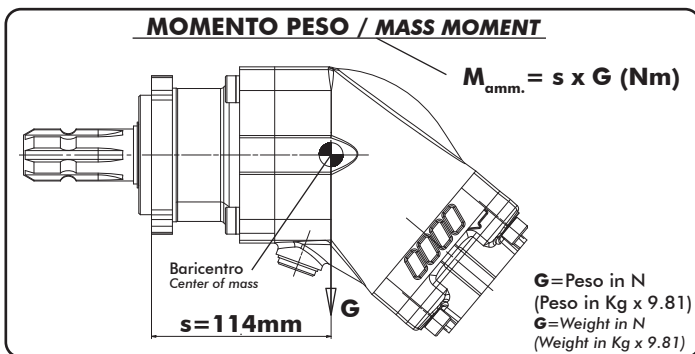
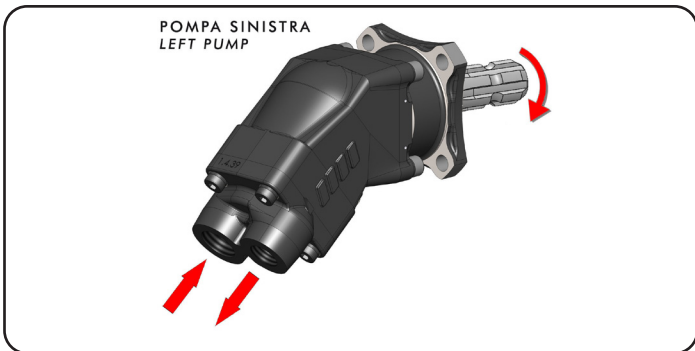

SCELTA DEL TUBO DI ASPIRAZIONE
HOW TO CHOOSE THE SUCTION PIPE SIZE

Q Portata Flow l/min	Ø interno min. tubo Min pipe diam.		Velocità flusso Flow speed (m/s)
	mm	inch	
20	25	1"	0,68
30	32	1" 1/4	0,62
40	32		0,83
50	38	1" 1/2	0,74
60	38		0,88
70	40	1" 9/16	0,93
80	45	1" 3/4	0,84
90	45		0,94
100	50	2"	0,85
110	50		0,93
120	60	2" 3/8	0,71
130	60		0,77
140	60		0,83
150	60		0,88
160	63	2" 1/2	0,86
170	63		0,91
180	63		0,96

Per garantire corrette condizioni di aspirazione la velocità del flusso non deve superare 1 m/sec.
To ensure the proper suction pipe size the flow speed should not exceed 1mt/sec.